



SETH GYANIRAM BANSIDHAR PODAR COLLEGE

Podar Educational Campus, Nawalgarh - 333042 (Raj.)

Website: www.podarcollege.com

3.2.1 Institution has created an ecosystem for innovations and has initiatives for creation and transfer of knowledge (Patents filed, published, incubation center facilities in the HEI to be considered)

3.2.1. INDEX

1. Copy of Different cells and their works
2. Activities done under Research and Development cell.
3. Seminars details under Entrepreneurship and Skill Development Cell.
4. Proposal details of Vocational Courses under National Skill Quality Framework (Syllabus, Ordinance and Course Structure).
5. Details of Counselling Cell and activities under this cell (Webinar, Seminar etc.)

Copy of Different Related Cells and their works



SETH GYANIRAM BANSIDHAR PODAR COLLEGE

Podar Educational Campus, Nawalgarh - 333042 (Raj.)

MEMBER OF ADVISORY COMMITTEE

5/01/2022

1. Dr. Satyendra Singh : Chairman
2. Prof. Seema Bhadauria : External Member
Principal, Balwant Vidhyapeeth Rural Institute, Agra
3. Prof. Ramesh Gaur : External Member
Academic Director, Indira Gandhi Centre for Arts, Delhi & Director National School of Drama
4. Dr. Achal Pandya : External Member
Conservation Head, Indira Gandhi Centre for Arts, Delhi
5. Mr. Ramesh Chand : External Member
Archives Officer, Regional Archives Agra
6. Dr. Ravindra Singh : External Member
Head, Department of English, K.K.P.G. College, Etawah (CSJM University, Kanpur)
7. Dr. Neelam Yadav : External Member
Head, Department of Linguistics, K.M. Institute of Hindi & Linguistics, Dr. BRA University, Agra
8. Dr. S.K. Soni : External Member
Head Department of Botany, Dayalbagh Education Institute, Agra
9. Director General : Academician Member
NRLC, Lucknow
10. Prof. Ambika Patel : Academician Member
Head, Conservation Department, M.S. University, Vadodara & President ICOM India
11. Prof. M.K Salooja Former Director : Academician Member
School of Agriculture, IGNOU, New Delhi
12. Dr. Bina Senger, Director : Academician Member
School of Liberal Arts, DBAM University, Aurangabad
13. Dr. Bhujang Ramrao Bobade : Academician Member
Head, Knowledge Resource Centre & Coordinator, Research (Research for Resurgence Foundation, Nagpur, Maharashtra)
14. Ms. Priyanka Bali : Member
(ASSCI Sector Skill Representative)
15. Ms. Srijita Dutta : Member
(FICSI, Sector Skill Representative)
16. Dr. Sunita Bhadwar : Member
(THSC, Sector Skill Representative)
17. Ms. Monica Bahl : Member
(Sector Skill Representative)
18. Ms. Sohini Guha : Member
(B&WSSC, Sector Skill Representative)
19. Dr. Ravindra Goswami : Member Secretary
20. Mr. Chetan Dadheech : Member
21. Dr. Harsh Kumar : Member
22. Dr. Bhupendra Rathore : Member
23. Dr. Dau Lal Bohar : Member
24. Mr. Rakesh Mahala : Member
25. Er. Rajkumar Saxena : Member

5/01/22
Principal

Seth G.B. Podar College
Nawalgarh - 333042



SETH GYANIRAM BANSIDHAR PODAR COLLEGE

Podar Educational Campus, Nawalgarh - 333042 (Raj.)

Ref. No.: GBPC/2020-21/431
To,

Date: 05/01/2021

Incharge IQAC
Seth G. B. Podar College, Nawalgarh

Subject: Regarding constitution of Research and Development Cell for Innovative work for students

Dear Sir,

As we all know Research and innovations are needed in current education system. So as per recommendation of The Anandilal Podar Trust, Nawalgarh (Jhunjhunu) Rajasthan we constituted a Research and Development Cell for future Scientific work for students with faculty. Functions of this cell will be:

- Creating research culture among faculty members and students.
- Motivate to undertake minor and major research projects from various funding agencies.
- Identification and assisting for finance from Management as well as funding agencies like UGC, DST etc.
- Guidance for publication of research papers and articles in reputed Journals.

Research and Development Committee:

1. Dr Satyendra Singh, Principal (Convener)
2. Dr. K.B Sharma, Dean Science (Coordinator)
3. All HOD'S (Members)

Dr
05/01/2021

Dr Satyendra Singh,
(Principal)

Seth G. B. Podar College, Nawalgarh

Principal

Seth G.B. Podar College
Nawalgarh - 333042

CC to:

1. All Department HOD's
2. Principal Office
3. APT office, Nawalgarh
4. Nodal officer website (Mr Rakesh Mahala)



SETH GYANIRAM BANSIDHAR PODAR COLLEGE

Podar Educational Campus, Nawalgarh - 333042 (Raj.)

7.	Time Table Committee		Department	Signature	Functions of working Committee
I	Mr. Chetan Dadheech	Convener	Chemistry		<ul style="list-style-type: none"> The Committee shall plan and prepare time tables for regular classes, practical's and shall see to it that all departments are allocated equal number of classes during the academic session/ semester.
II	Dr. Vidyadhar Sharm	Member	Mathematics		
III	Mr. Shantilal Joshi	Member	Geography		
IV	Mr. Pramod Kumar Saini	Member	English		
V	Dr. Sanjay Saini	Member	B.Adm.		
VI	Dr. Neeraj Basotia	Member	EAFM		
VII	Mr. Rakesh Mahala	Member	Computer Science		
VIII	Mrs. Rachna	Member	Management Studies		

8.	Research and Consultancy Committee		Department	Signature	Functions of working Committee
I	Dr. D.L. Bohra	Convener	Zoology		<ul style="list-style-type: none"> To promote research attitude among the students. To promote faculty to apply for major and minor research projects for various funding agencies. To acquire skills of research, develop leadership as well as involve social activities for the benefit of mankind.
II	Mr. Chetan Dadheech	Member	Chemistry		
III	Dr. B.S. Rathore	Member	Physics		
IV	Dr. Neeraj Basotiya	Member	EAFM		
V	Dr. Ravindra Goswami	Member	Botany		

9.	Ecology and Biodiversity Conservation Club Committee		Department	Signature	Functions of working Committee
I	Dr. Ravindra Goswami	Convener	Botany		<ul style="list-style-type: none"> To make students aware about Ecology and Biodiversity Conservation. To organize activities for the conservation of Eco System. To conduct Green audit.
II	Ms. Shyama Didwania	Member	Botany		
III	Mr. Rajkumar Saxena	Member	Zoology		



SETH GYANIRAM BANSIDHAR PODAR COLLEGE

Podar Educational Campus, Nawalgarh - 333042 (Raj.)

13.	Students' Council Committee		Department	Signature	Functions of working Committee
I	Dr. Anil Sharma	Convener	Hindi		<ul style="list-style-type: none"> To promote an environment favourable for educational and personal development To support the management and staff in the development of the college. To represent the views of the students on matters of general concern to them.
II	Mr. Pramod Kumar Saini	Member	English		
III	Mr. Sudhir Jangir	Member	English		

14.	Competitive Examination Cell Committee		Department	Signature	Functions of working Committee
I	Mr. Shantilal Joshi	Convener	Geography		<ul style="list-style-type: none"> To provide special training and coaching for competitive examinations to students such as RPSC/UPSC/Other. To organize expert lectures on competitive examination for students.
II	Mr. Pramod Kumar Saini	Member	English		
III	Mr. Sudhir Jangir	Member	English		
IV	Mr. Jitendra Saini	Member	History		

15.	NSS Advisory Committee		Department	Signature	Functions of working Committee
I	Dr. Vinod Kumar Saini	Convener	Pol. Science		<ul style="list-style-type: none"> College NSS unit shall function according to the specified guidelines laid down by the NSS. To arrange discussions and workshops of group of students on regular basis on issues of social importance, ethical relevance and moral values. To arrange social service groups and outdoor field activities. To support and involve students in social service activities.
II	Mr. Rakesh Jangir Programme Officer (Unit - I)	Member	Zoology		
III	Ms. Shyama Deedwania Programme Officer (Unit - II)	Member	Botany		

Activities done under Research and Development Cell



SETH GYANIRAM BANSIDHAR PODAR COLLEGE

Podar Educational Campus, Nawalgarh - 333042 (Raj.)

Output data of sensor is applied to a current amplifier circuit and feed to a low power DC motor. We have made current amplifier by using a general purpose NPN transistor. I have used BC548 as shown in the circuit diagram. If you are using other NPN transistor, then make sure about pin configuration. Transistor will start conducting when base voltage reaches to 0.40 V (40 Degree). You will see fan start to rotate and at 0.60V (60 degree) it will be at full speed. At this voltage transistor is fully conducted means resistance is low .

Automatic Street Light

Introduction:

Needs project we have used four L.E.D as a symbol of street lamp, but for high power switching one can connect Relay (electromagnetic switch) at the output of pin 3 of I.C 555 that will make easy to turn ON/OFF any electrical no manual operation for switching ON and OFF. When there is a need of light it automatically switches ON. When darkness rises to a certain level then sensor circuit gets activated and switches ON and when there is other source of light i.e. daytime, the street light gets OFF. The sensitiveness of the street light can also be adjusted. In our appliances that are connected through relay.

Principal
Seth G.B. Podar College
Nawalgarh - 333042

Rambilas Podar Road, Nawalgarh Dist: Jhunjhunu - 333042

Phone No: 01594- 222030, 225892 Fax No: 01594-223198

Web Site: www.podarcollege.com E-Mail: principal@podarcollege.com





SETH GYANIRAM BANSIDHAR PODAR COLLEGE

Podar Educational Campus, Nawalgarh - 333042 (Raj.)



Principle:

This circuit uses a popular timer I.C 555. I.C 555 is connected as comparator with pin-6 connected with positive rail, the output goes high(1) when the trigger pin 2 is at lower than $1/3$ rd level of the supply voltage. Conversely the output goes low (0) when it is above $1/3$ rd level. So small change in the voltage of pin-2 is enough to change the level of output (pin-3) from 1 to 0 and 0 to 1. The output has only two states high and low and can not remain in any intermediate stage. It is powered by a 6V battery for portable use. The circuit is economic in power consumption. Pin 4, 6 and 8 is connected to the positive supply and pin 1 is grounded. To detect the present of an object we have used LDR and a source of light. LDR is a special type of resistance whose value depends on the brightness of the light which is falling on it. It has resistance of about 1 mega ohm when in total darkness, but a resistance of only about 5k ohms when brightness illuminated. It responds to a large part of light spectrum. We have made a potential divider circuit with LDR and 100K variable resistance connected in series. We know that voltage is

Rambilas Podar Road, Nawalgarh Dist: Jhunjhunu - 333042

Phone No: 01594- 222030, 225092 Fax No: 01594-223198

Web Site: www.podarcollege.com E-Mail: principal@podarcollege.com

Principal
Principal
Seth G.B. Podar College
Nawalgarh - 333042



SETH GYANIRAM BANSIDHAR PODAR COLLEGE

Podar Educational Campus, Nawalgarh - 333042 (Raj.)

directly proportional to conductance so more voltage we will get from this divider when LDR is getting light and low voltage in darkness. This divided voltage is given to pin 2 of IC 555. Variable resistance is so adjusted that it crosses potential of $1/3$ rd in brightness and fall below $1/3$ rd in darkness. Sensitiveness can be adjusted by this variable resistance. As soon as LDR gets dark the voltage of pin 2 drops $1/3$ rd of the supply voltage and pin 3 gets high and LED or buzzer which is connected to the output gets activated.

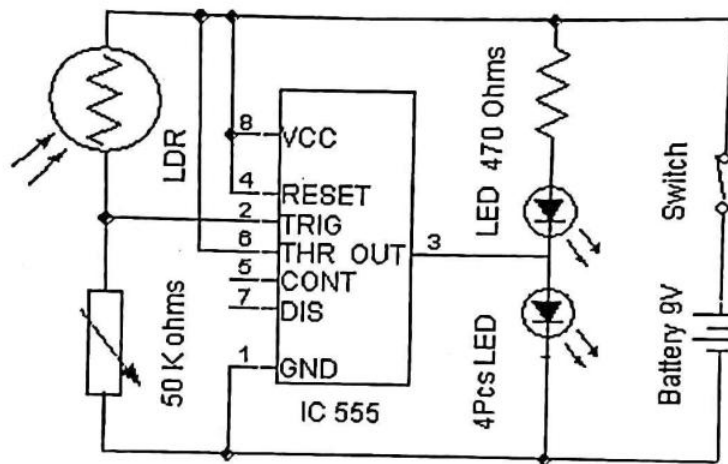

Circuit Diagram of Automatic Street Light

Transistor as a Switch

luc
Principal
Seth G.B. Podar College
Nawalgarh - 333042

Rambilas Podar Road, Nawalgarh Dist: Jhunjhunu - 333042

Phone No: 01594-222030, 225892 Fax No: 01594-223198

Web Site: www.podarcollege.com E-Mail: principal@podarcollege.com

Signature



SETH GYANIRAM BANSIDHAR PODAR COLLEGE

Podar Educational Campus, Nawalgarh - 333042 (Ra.)

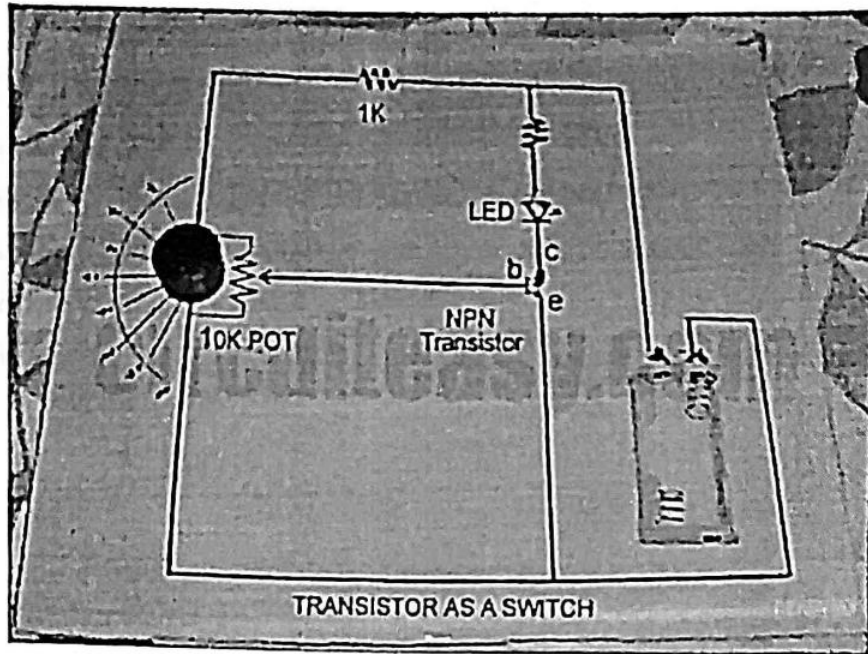

Transistor as a switch

Solid state materials can be grouped in to 3 classes:- Insulators, Conductors and Semiconductors. Semiconductor material is neither conductor nor insulator. It has conductivity between conductors and insulators and is sensitive to temperature, illumination, magnetic field and minute amount of impurity atoms. This type of sensitive material for controlling or switching current is very much required in modern age. Today electronics device means present of semiconductor devices.

Semiconductor Devices are the foundation of electronics industry. For advance courses in electronics it is necessary to have basic knowledge of Semiconductor device. A common semiconductor device is a Transistor.

Aim of this project is to determine characteristic of a NPN transistor by varying base voltage and detect Cut-off Region and Saturation Region.

We have used a potentiometer for varying Base voltage. After assembling the circuit use a digital multimeter and scale mark the voltage. You can also attach a multimeter permanently. A low power indicator such as LED is used for detection of conductance of transistor. LED is connected

Signature

Principal

SETH G.B. Podar College
Nawalgarh - 333042

Rambhass Podar Road, Nawalgarh Dist: Jhunjhunu - 333042
Phone No: 01594- 222030, 225892 Fax No: 01594-223198

Web Site: www.podarcollege.com E-Mail: principal@podarcollege.com

Signature



SETH GYANIRAM BANSIDHAR PODAR COLLEGE

Podar Educational Campus, Nawalgarh - 333042 (Raj.)

to power supply through collector of transistor so that when transistor is conducted then circuit will be complete and led glows.

After making the project. Place the battery and start rotating nobe of POT. You will see LED starts glowing after reaching .5V and at .7V it will light Dark. Thus you can mark cut off region (fully off) and Saturation Voltage (full dark). Most of the transistor will conduct from .5 to .7 Volt. This type of circuit is commonly used in voltage stabilizer for high voltage cut off. A relay is placed at LED connection.

Sup
Principal
Seth G.B. Podar College
Nawalgarh - 333042

Rambilas Podar Road, Nawalgarh Dist: Jhunjhunu - 333042

Phone No: 01594- 222030, 225892 Fax No: 01594-223198

Web Site: www.podarcollege.com E-Mail: principal@podarcollege.com

W.P. Thome



SETH GYANIRAM BANSIDHAR PODAR COLLEGE

Podar Educational Campus, Nawalgarh - 333042 (Raj.)

Rain Alarm

GIVES BEEP WHEN WATER IS IN CONTACT WITH THE WIRE

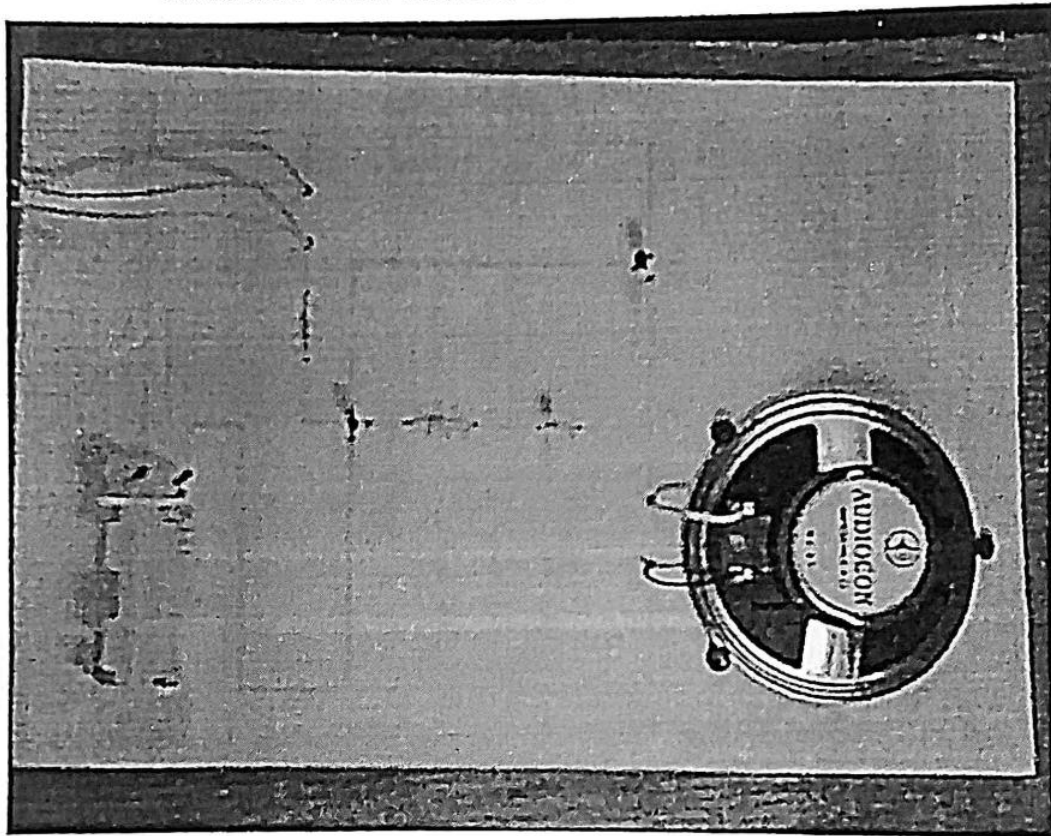

Rain Alarm Project

Here is an interesting electronics project to detect if there is raining or not. Same circuit can also be used as water level indicator or as a tank overflow indicator.

Working: Water is a conductor of electricity. When water is in contact with the probe then there is a flow of current toward the base of NPN transistor (BC548), which conducts. With the conduction of NPN transistor, electron reaches to Q2, which is a PNP transistor. PNP transistor (BC558) also conducts and current flows through the speaker. In a speaker there is inductive coil which causes motion in one direction and after that produces induce current, which is in opposite direction to the flow of current this induced current in the form of pulse, flows through a capacitor, resistance and makes 1st transistor BC548 off for an inter-well and after-that it relaxes to previous state. This process repeats again and

Rambhass Podar Road, Nawalgarh Dist: Jhunjhunu - 333042

Phone No: 01594-223030, 225892 Fax No: 01594-223198

Web Site: www.podarcollege.com E-Mail: principal@podarcollege.com

Principal
Seth G.B. Podar College
Nawalgarh - 333042



SETH GYANIRAM BANSIDHAR PODAR COLLEGE

Podar Educational Campus, Nawalgarh - 333042 (Raj.)

again till probe is in contact with water and an oscillation is created in the circuit. Speaker diaphragm vibrates and gives a tone. Frequency of the circuit depends on the value of Coil impedance, Capacitor and Resistance Value.

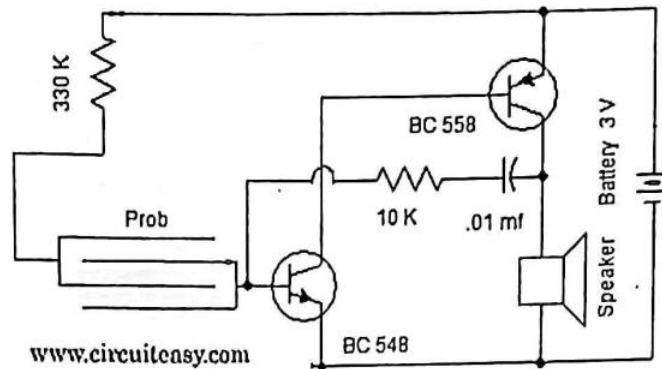

Circuit Diagram of Rain Alarm

me
Principal
Seth G.B. Podar College
Nawalgarh - 333042

Rambilas Podar Road, Nawalgarh Dist: Jhunjhunu - 333042

Phone No: 01594- 222030, 225892 Fax No: 01594-223190

Web Site: www.podarcollege.com E-Mail: principal@podarcollege.com

Rambilas Podar



SETH GYANIRAM BANSIDHAR PODAR COLLEGE

Podar Educational Campus, Nawalgarh - 333042 (Raj.)

Smart Walking Stick for Blind And Old Aged People

A foot stick based totally on ultrasonic sensors and Arduino for visually impaired human beings. People with seen disabilities are often relying on outdoor help which may be provided with the beneficial resource of people, educated puppies, or unique virtual gadgets as assist structures for desire making. Thus, we had been endorsed to growth a clever white cane to overcome the ones boundaries. We finished this cause with the beneficial useful resource of the use of adding ultrasonic sensors at particular positions to the cane that supplied statistics about the surroundings to the customer via the usage of manner of activating the buzzer sound.

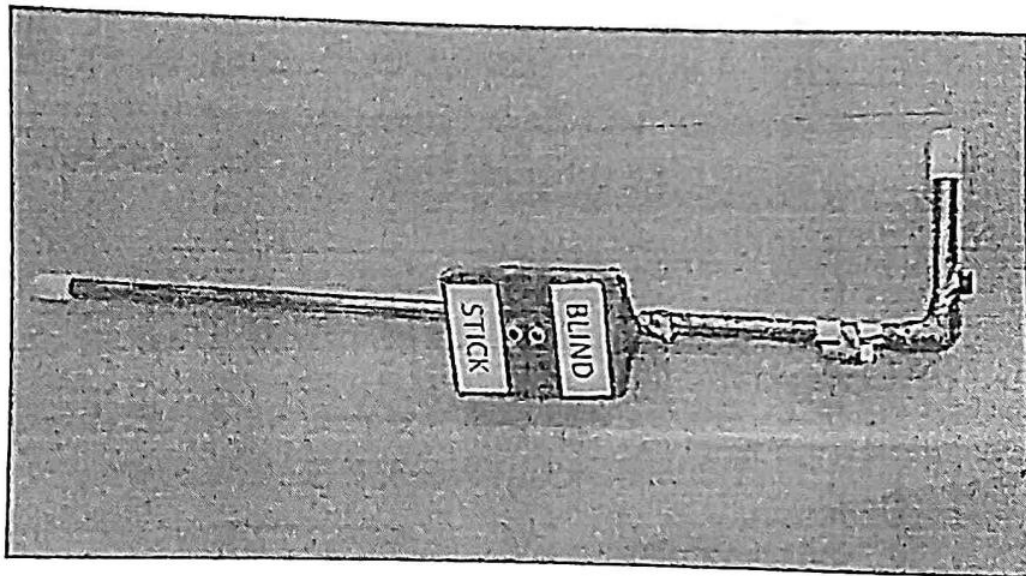

Principal
Principal
Seth G.B. Podar College
Nawalgarh - 333042

Rambilas Podar Road, Nawalgarh Dist: Jhunjhunu - 333042

Phone No: 01594- 222030, 225892 Fax No: 01594-223198

Web Site: www.podarcollege.com E-Mail: principal@podarcollege.com

Seminars details under Entrepreneurship and Skill Development Cell



A
REPORT
ON
ENTREPRENEURSHIP

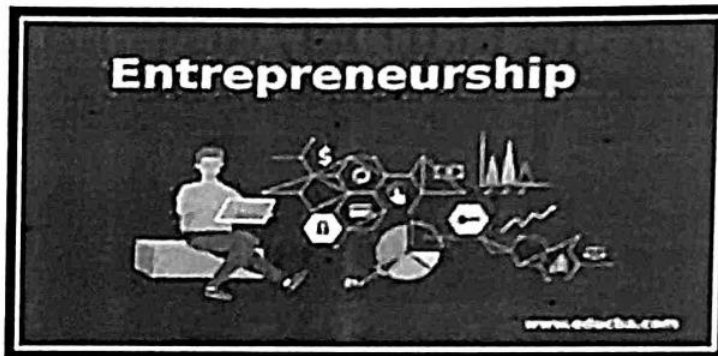

Seminar Title : Entrepreneurship
Seminar Venue : PIMS Room No. 41
Date : 11/03/2022
Duration : 10.40 am to 11.40 pm
Organized by : PIMS Department
Present : Prof. Rajesh Verma, Prof. Mukesh Saini,
Ms. Rachna & Dr. Uma Soni
Delivered by : Prof. Narendra Saini
Beneficiaries : 50 Students (All BBA & BCA)
Distribution : IQAC & Principle Office



SETH GYANIRAM BANSIDHAR PODAR COLLEGE
Podar Educational Campus, Nawalgarh, Rajasthan, 333042
Website: www.podarcollege.com, Phone: 01594-222030

Ref. No – GBPC/2021-22/PC/

Date: 05-03-2022

To,

The Principal,

Seth G. B. Podar College, Nawalgarh.

Subject: Regarding Sanction for Seminar

Respected Sir,

With reference to our meeting held in your office regarding organizing Seminars for the students of PIMS (BBA and BCA).

A seminar will be organized on the 11th March, 2022. The topic of the seminar is “Entrepreneurship” and will be delivered by Prof. Narendra Saini (Professor, Seth G. B. Podar College, and Nawalgarh).

The Seminar will be held in the PIMS department auditorium from 10:40 am to 11:40 pm.

Considering the above please provide the sanction to conduct the seminar.

Regards,

HOD PIMS

Principal

Copy to:-

1. IQAC, Podar College
2. Notice Board
3. Office Record



SETH GYANIRAM BANSIDHAR PODAR COLLEGE

Podar Educational Campus, Nawalgarh, Rajasthan, 333042

Website: www.podarcollege.com, Phone: 01594-222030

Ref.No GBPC/PIMS/2022/

Date: 09-03-2022

Notice

This is to inform all BBA and BCA student that a seminar on “**Entrepreneurship**” will be organized on the 11th of March, 2022.

The seminar will be delivered by **Prof. Narendra saini** (Professor, Seth G. B. Podar College, and Nawalgarh). The seminar will be held in the **PIMS Room Number 41** from 11:00 am to 01:00pm.

All the students are instructed to attend the seminar Mandatory.

HOD PIMS

Principal

Copy to:-

1. CEO, The Anandilal Podar Trust, Nawalgarh
2. IQAC, Podar College
3. PIMS Department
4. Notice Board

Introduction:

Entrepreneurs are people that observe opportunities and take the initiative to prepare resources to make new goods and services.

Objectives:

1. To develop and strengthen the quality of entrepreneurship.
2. To removing unemployment.
3. To enhance industrial development.
4. To understand the process and procedure involved in setting up small units.
5. To know the sources of help and support available for starting a small-scale industry.
6. To acquire the necessary managerial skill required to run the industrial unit.
7. To helping the person to understand environmental changes and opportunities.

Steps for Successful Growth of Entrepreneurship:

1. Determination of Objective:

When we start a business, first determine the objectives. After determining the objectives, the process of accomplishment is to be decided. The objectives may be short term or long term.

2. Planning:

Planning is the need of the hour. Planning is important for any business to solve problems and their relative solutions. The success of a business largely depends on proper planning.

Finance:

Finance is the life blood of every business activity. Planning is not possible without Finance.

Appropriate location, layout and size:

The entrepreneur has to be very careful in selecting an appropriate location. The availability of raw material, labour supply, electricity, capital market transport facilities. The business may be large, medium or small. The decision regarding the same is taken by the entrepreneur.

Research facilities:

In present Situation of changing technology & increasing competition, it is necessary to have the right information from the view point of business. An innovative entrepreneur always goes for something new.

Efficient and dynamic leadership:

Leadership is the ability to obtain desired results out of the efforts of a group. The success or failure of a business largely depends on leadership.

About Event:

A Seminar was held under the aegis of PIMS Department at Seth G.B .Podar College, run by The Anandilal Podar Trust, in which Dr. Satyendra singh, Principal, Dr. Vinod Kumar Saini, Vice Principal and all faculty members of PIMS department (Prof. Rajesh Verma , Prof. Narendra Saini, Dr. Uma Soni & Prof. Mukesh Saini) were present in this seminar. Prof. Mukesh Saini started the program to introduce the seminar topic and seminar expert. Speaker of this Seminar, Prof. Narendra Saini (Asst. Professor at Seth .G.B. Podar College, Nawalgarh) shared her excellent knowledge about "Entrepreneurship". Prof. Narendra Saini apprised that Entrepreneurship is the ability to observe the opportunities to support an organization and discuss some points about Successful and Unsuccessful Entrepreneurs:

For Successful Entrepreneurs:

- Creative and Innovative
- Position themselves in shifting or new markets
- Create new products
- Create new processes
- Create new delivery

For Unsuccessful Entrepreneurs:

- Poor Managers
- Low work ethic
- Inefficient
- Failure to plan and prepare
- Poor money managers

Mr. Narendra Saini shared Characteristics of Entrepreneurship in an organization. An entrepreneur should have Key Personal Attributes, Strong Managerial Competencies & Good Technical Skills. Ms. Rachna concluded the program with thanks to the Prof. Narendra Saini and said that Entrepreneurship is necessary for an organization to achieve defined objectives.

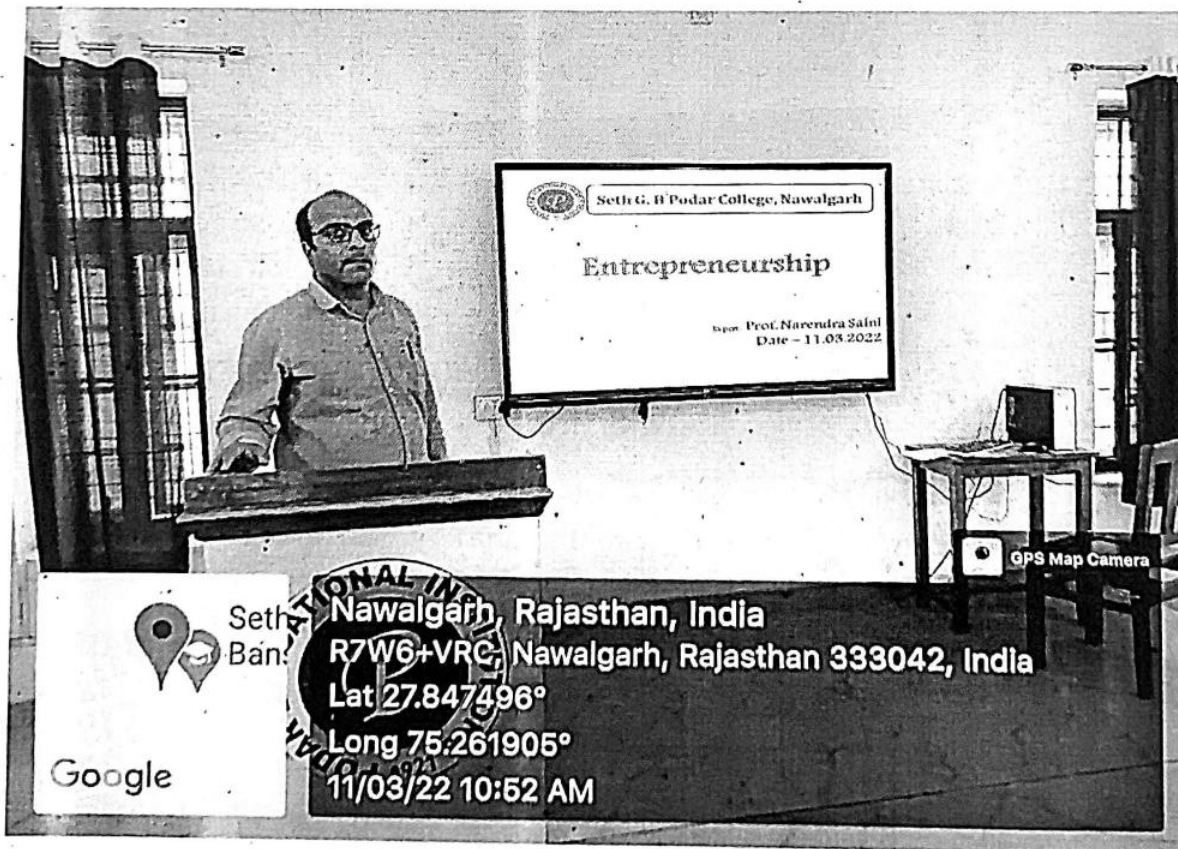
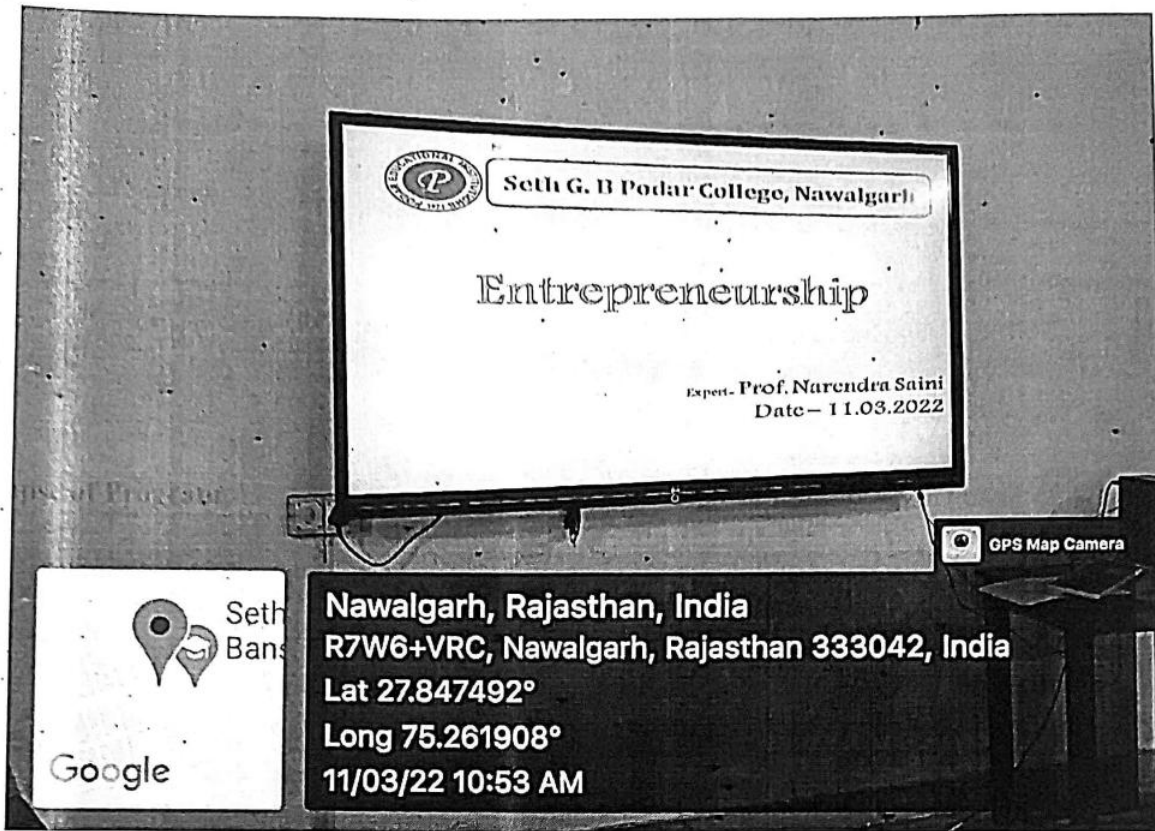



PODAR INSTITUTE OF MANAGEMENT STUDIES

Seth G B Podar College, Nawalgarh

Seminar on "Entrepreneurship"

List of Participants

S.No	Name of Student	Father's Name	Class	Signature
1.	Pavankumar	Mr. Satish Kumar	BCA 1st	Pavankumar
2.	Rahul Saini	Mr. Balram Sen	BCA 1st	Rahul Sen
3.	Nurej Jangir	Suresh Jangir	BCA 1st	Nurej
4.	Nirmal Saini	Gulabchand Saini	BCA 1st	Nirmal
5.	Ashutosh Sharma	Sushil Sharma	BCA 1st	Ash
6.	Monti Saini	Bashesharlal Saini	BCA 1st	Monti
7.	Aditya Kumawat	Ramswaroop Kumawat	BCA 1st	Aditya
8.	Dipendra Singh	Omud Singh	BCA 1st	Ds
9.	Pannam Saini	Rajendra Kumar Saini	B.C.A. 1st	Pannam
10.	Krishan Kumawat	Mr. Raju Kumawat	B.C.A. 1st	Krishan
11.	Abhinav Chhorela	Rakesh Chhorela	B.C.A. 1st	Abhinav
12.	Mubani	Abdul Shakur	B.C.A. 1st	Mubani
13.	Aakash	Rahim Ahmed	BCA 1st	Aakash
14.	Khalid Ahmad	Samudhak	BCA 1st	Khalid
15.	Harshad	Subhas	BCA 1st	Harshad
16.	Anurag	Purneshottam	BCA 1st	Anurag
17.	Aakash	Rahim Ahmed	BCA - 1st	Aakash
18.				
19.				
20.				



PODAR INSTITUTE OF MANAGEMENT STUDIES

Seth G B Podar College, Nawalgarh

Seminar on "Entrepreneurship"

List of Participants

S.No	Name of Student	Father's Name	Class	Signature
1.	SAMEER	Mo. Mahdosh	BCA III	
2.	Sonu Sharma	Mr. Ravishankar	BCA-II	
3.	Khushi Sharma	Mr. Sunil Sharma	BCA-III	
4.	Vishal Sharma	Mr. Manoj Kumar	BCA-I	
5.	Mukesh Kumar	Mr. Ravishankar Kumar	BCA-I	
6.	Vikash	Radheshyam Saini	BCA-I	
7.	Arshad Khan	Mohd. Asgar Khan	BCA III	
8.	Ammar	Jamil	BCA III	
9.	Aakash	Rehman Ahmed	BCA-I	
10.	Abhinav Choudhary	Rakesh Choudhary	BCA-I	
11.	Harish Choudhary	Rajiv Kumar	BCA-I	
12.	Vishal			
13.				
14.	ABHISHEK SAINI	Satyajayam Saini	BCA II	
15.				
16.				
17.				
18.				
19.				
20.				



PODAR INSTITUTE OF MANAGEMENT STUDIES

Seth G B Podar College, Nawalgarh

Seminar on "Entrepreneurship"

List of Participants

S.No	Name of Student	Father's Name	Class	Signature
1.	SAMEER	Mo. Mahboob	BCA III	
2.	Sonu Sharma	Mr. Ravishankar	BCA-II	
3.	Khushi Saraf	Mr. Sunil Saraf	BCA-III	
4.	Vishal Sharma	Mr. Maniramji	BCA-I	
5.	Mukesh Kumar	Urooishankar Kumar	BCA-I	
6.	Vikash	Radheshyam Saini	BCA-I	
7.	Arshad Khan	Mohd. Asgar Khan	BCA III	
8.	Ammar	Jamil	BCA-II	
9.	Aakash	Rehman Ahmed	BCA-I	
10.	Abhay Chhorela	Rakesh Chhorela	BCA-I	
11.	Wishnu Kumar	Rajju Kumar	BCA-I	
12.	Vishal	Manoj	BCA-I	
13.				
14.	ABHISHEK SAINI	Sudhyanandan Saini	BCA II	
15.				
16.				
17.				
18.				
19.				
20.				



PODAR INSTITUTE OF MANAGEMENT STUDIES

Seth G B Podar College, Nawalgarh

Seminar on "Entrepreneurship"

List of Participants

S.No	Name of Student	Father's Name	Class	Signature
1.	Pawan Kumar	Mr. Satish Kumar	BCA Ist	Pkumar
2.	Rahul Sen	Mr. Balram Sen	BCA Ist	Rahlsen
3.	Nurej Jangeir	Suresh Jangeir	BCA Ist	nurej
4.	Nirmal Saini	Gulabchand Saini	BCA Ist	Nirmal
5.	Ashutosh Sharma	Sushil Sharma	BCA Ist	Ash
6.	Monti Saini	Bashesharlal Saini	BCA Ist	Monti
7.	Aditya Kumawat	Rameshwaroop Kumawat	BCA Ist	Aditya
8.	Dipendra Singh	Omrad Singh	BCA Ist	Ds
9.	Parvati Saini	Rajendra Kumar Saini	B.C.A. Ist	Parvati
10.	Krishan Kumawat	Mr. Raju Kumawat	B.C.A. Ist	Krishan
11.	Abhay Chhorela	Rakesh Chhorela	B.C.A. Ist	Abhay
12.	Mubani	Abdul Shakur	B.C.A. Ist	Mubani
13.	Aakash	Rohim Ahmed	BCA Ist	Aakash
14.	Khalid Ahmad	Samsul Haq	BCA Ist	Khalid
15.	Harshad	Subhas	BCA Ist	Harshad
16.	Anurag	Purushottam	BCA Ist	Anurag
17.	Aakash	Rohim Ahmed	BCA - Ist	Aakash
18.				
19.				
20.				



Seth G. B. PODAR COLLEGE, NAWALGARH

Podar Educational Campus, Nawalgarh - 333042 (Raj.)

Seminar on "Entrepreneurship" Feedback Form

Name of the Expert : Prof. Narendra Saini
 Date & Time of Seminar/Workshop : 11 March, 11:00 AM – 12:00 AM
 Name of the Participant : *Prabha Sakshi*
 Department/Stream : *PIMS*

❖ Please respond to the following statements by using 4 points rating scale indicating the extent to which you agree or disagree. Please choose the appropriate response.

A- Completely Agree
 C- Average

B- Agree
 D- Poor

1	The Presenter was well prepared and organized	A
2	The Presenter had good subject knowledge	B
3	The materials used were in line with the seminar	B
4	The Presenter communicated in a way that everyone understood	A
5	The program was useful and relevant data was shared	B
6	The program honed the knowledge, Skills and Attitude	A
7	The presenter supported the seminar with good and relevant examples	B
8	The presenter made good use of the time allotted	A
9	The length of the program was appropriate	B
10	The presenter resolved all queries satisfactorily at the end of the program	A

❖ What one thing would you recommend to improve such program?

No recommendation

❖ What did you liked the most in the program.

Very useful for us. Everything good.

Prabha Sakshi
Signature

ORGANISED
 BY
 Department of PIMS



Seth G. B. PODAR COLLEGE, NAWALGARH
Podar Educational Campus, Nawalgarh - 333042 (Raj.)

Seminar on "Entrepreneurship"
Feedback Form

Name of the Expert : Prof. Narendra Saini
Date & Time of Seminar/Workshop : 11 March, 11:00 AM – 12:00 AM
Name of the Participant : *Nehika - Kataruiya*
Department/Stream : *PIMS*

❖ Please respond to the following statements by using 4 points rating scale indicating the extent to which you agree or disagree. Please choose the appropriate response.

A- Completely Agree
C- Average

B- Agree
D- Poor

1	The Presenter was well prepared and organized	A
2	The Presenter had good subject knowledge	B
3	The materials used were in line with the seminar	B
4	The Presenter communicated in a way that everyone understood	A
5	The program was useful and relevant data was shared	A
6	The program honed the knowledge, Skills and Attitude	A
7	The presenter supported the seminar with good and relevant examples	B
8	The presenter made good use of the time allotted	A
9	The length of the program was appropriate	A
10	The presenter resolved all queries satisfactorily at the end of the program	A

❖ What one thing would you recommend to improve such program?

No.

❖ What did you liked the most in the program.

Everything is Good.

Nehika
Signature

ORGANISED
BY
Department of PIMS



**Seminar on "Entrepreneurship"
Feedback Form**

Name of the Expert : Prof. Narendra Saini
Date & Time of Seminar/Workshop : 11 March, 11:00 AM – 12:00 AM
Name of the Participant : ...Rahul.....
Department/Stream :B.C.A.II.....

❖ Please respond to the following statements by using 4 points rating scale indicating the extent to which you agree or disagree. Please choose the appropriate response.

A- Completely Agree
C- Average

B- Agree
D- Poor

1	The Presenter was well prepared and organized	A
2	The Presenter had good subject knowledge	A
3	The materials used were in line with the seminar	A
4	The Presenter communicated in a way that everyone understood	A
5	The program was useful and relevant data was shared	B
6	The program honed the knowledge, Skills and Attitude	B
7	The presenter supported the seminar with good and relevant examples	A
8	The presenter made good use of the time allotted	A
9	The length of the program was appropriate	A
10	The presenter resolved all queries satisfactorily at the end of the program	A

❖ What one thing would you recommend to improve such program?

.....

❖ What did you liked the most in the program.

.....

Signature

**ORGANISED
BY
Department of PIMS**



Department of Computer Science and Management
Seth G B Podar College, Nawalgarh

Report of Expert Lecture Conducted

Date	:	13 th March 2021
Time	:	01:00 PM onwards
Place	:	PIMS, Room No. 41
Resource Person	:	Mr. Hitesh Sharma working with TCS Ahmadabad
Organized by	:	PIMS Faculty
Present	:	Prof. Rakesh Kumar, Dr. Harshit Sharma, Prof. Madhu Saini, Prof. Anil Kumar Chotiya, Prof. Jyoti Khandelwal,
Participants	:	Students of BCA and BBA
Distribution	:	IQAC & Principal Office

Expert Lecture on “Career Counseling”

The objective of this guest lecture is to create awareness among the outgoing students on the steps for success in interviews. The Program was started with invocation followed by brief introduction about the resource person. The session started with the key points for preparation to a successful interview and practice. The suggestions given during lecture sessions are as follows:

1. Self-Evaluation

2. Before the Interview

- a. Research the company
- b. Practice interviews
- c. Dress professionally
- d. Arrive early

3. During the Interview

- a. First impressions (only in 30 seconds)

Principal

Seth G.B. Podar College
Nawalgarh - 333042

- b. Smile
 - c. Body Language
 - d. Speak clearly
 - e. Listen before answering
 - f. Give brief answers
 - g. Previous employers
 - h. Be truthful
 - i. Know your resume
 - j. Keep things at a professional level
- 4. After the Interview**
- a. Back in touch
 - b. Get everyone's business card
 - c. Thank the interviewer

After this session guidance has been given for **Group Discussion**. The students have shown their interest in interacting with the resource person regarding the common interview questions and positive and negative point in G.D. The lecture sessions were very informative and highly interactive for our final year students. At the end, feedback was taken and the session ended up with vote of thanks delivered by Dr. Harshit Sharma.



Principal

Seth G.B. Podar College
Nawalgarh - 333042

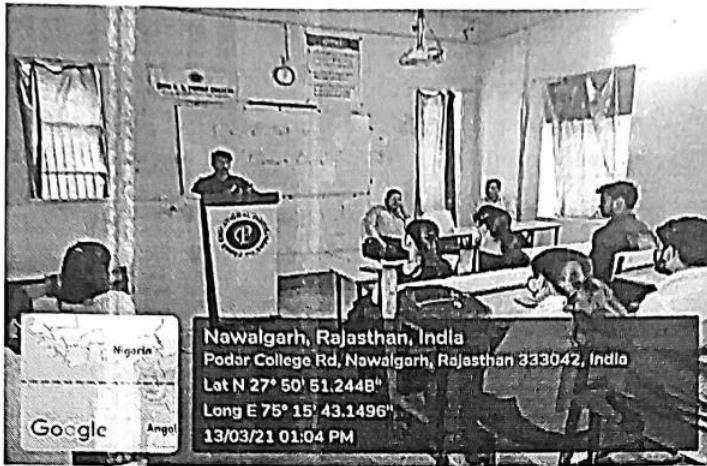

Dignitaries on the Dias & Speaker Addressing Students

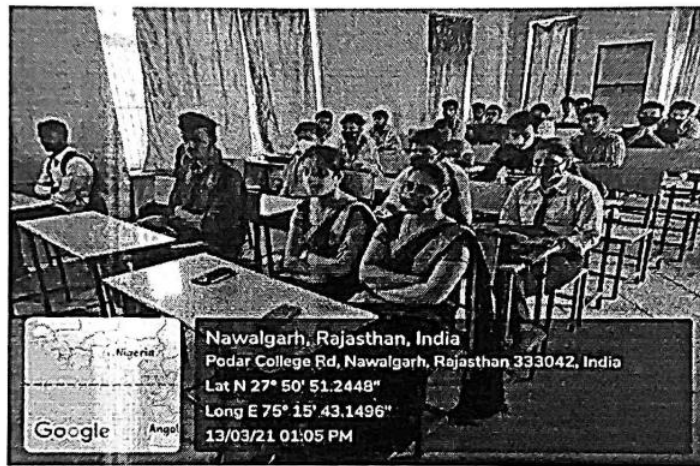

Department Staff and Students

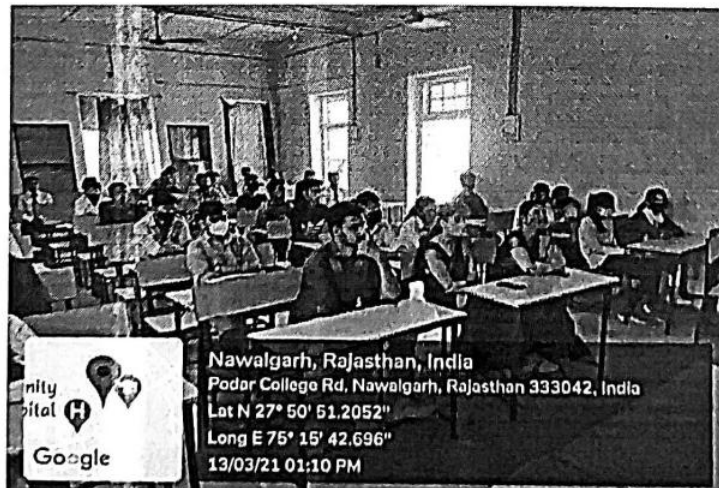

Lecture Session

Principal

**Seth G.B. Podar College
Nawalgarh - 333042**

Proposal of Vocational Courses under NSQF

(Syllabus, Ordinance and Course Structure)



SETH GYANIRAM BANSIDHAR PODAR COLLEGE

Podar Educational Campus, Nawalgarh - 333042 (Raj.)

MEMBER OF ADVISORY COMMITTEE

5/01/2022

1. Dr. Satyendra Singh : Chairman
2. Prof. Seema Bhadauria : External Member
Principal, Balwant Vidhyapeeth Rural Institute, Agra
3. Prof. Ramesh Gaur : External Member
Academic Director, Indira Gandhi Centre for Arts, Delhi & Director National School of Drama
4. Dr. Achal Pandya : External Member
Conservation Head, Indira Gandhi Centre for Arts, Delhi
5. Mr. Ramesh Chand : External Member
Archives Officer, Regional Archives Agra
6. Dr. Ravindra Singh : External Member
Head, Department of English, K.K.P.G. College, Etawah (CSJM University, Kanpur)
7. Dr. Neelam Yadav : External Member
Head, Department of Linguistics, K.M. Institute of Hindi & Linguistics, Dr. BRA University, Agra
8. Dr. S.K. Soni : External Member
Head Department of Botany, Dayalbagh Education Institute, Agra
9. Director General : Academician Member
NRLC, Lucknow
10. Prof. Ambika Patel : Academician Member
Head, Conservation Department, M.S. University, Vadodara & President ICOM India
11. Prof. M.K Salooja Former Director : Academician Member
School of Agriculture, IGNOU, New Delhi
12. Dr. Bina Senger, Director : Academician Member
School of Liberal Arts, DBAM University, Aurangabad
13. Dr. Bhujang Ramrao Bobade : Academician Member
Head, Knowledge Resource Centre & Coordinator, Research (Research for Resurgence Foundation, Nagpur, Maharashtra)
14. Ms. Priyanka Bali : Member
(ASSCI Sector Skill Representative)
15. Ms. Srijita Dutta : Member
(FICSI, Sector Skill Representative)
16. Dr. Sunita Bhadwar : Member
(THSC, Sector Skill Representative)
17. Ms. Monica Bahl : Member
(Sector Skill Representative)
18. Ms. Sohini Guha : Member
(B&WSSC, Sector Skill Representative)
19. Dr. Ravindra Goswami : Member Secretary
20. Mr. Chetan Dadheech : Member
21. Dr. Harsh Kumar : Member
22. Dr. Bhupendra Rathore : Member
23. Dr. Dau Lal Bohar : Member
24. Mr. Rakesh Mahala : Member
25. Er. Rajkumar Saxena : Member

5/01/22
Principal

Seth G.B. Podar College
Nawalgarh - 333042



SETH GYANIRAM BANSIDHAR PODAR COLLEGE
Podar Educational Campus, Nawalgarh - 333042 (Raj.)

Ref.No./GBPC/2021-22/306

Date: - January 07, 2022

To

The Registrar,
Pandit Deendayal Upadhyay Shekhwati University,
Sikar, Rajasthan

Subject: Letter of intent and proposal to start skill course under UGC NSQF scheme

Dear Sir,

We are running UG and PG courses in all the stream of Science, Arts and Commerce under self financing category after grant in aid was stopped by the State Government since July, 2011.

The College has been recognized by UGC under Section 12 B AND 2F.

New education Policy 2020 has already been launched and UGC has proposed to take initiative for apprenticeship/ internship embedded degree program as part of curriculum of general degree program and to facilitate vocational education to enhance employability.

In this context, I feel pleasure to present intent of our College Management to run skill based vocational courses under NSQF scheme of UGC from the session 2022-23.

Thus, we are submitting proposal of the following courses along with their detailed Syllabus, copy of ordinances of UGC for Bachelor of Vocation program, and examination & assessment Regulations for your perusal and observation:

1. B. Voc. in Organic Farming and Organic Products
2. B. Voc. in Ecotourism and Conservation of Cultural Heritage
3. B. Voc. in Nutrition and Health Care
4. B. Voc. in Dairy Technology

I request you kindly to forward the proposal to the Academic Council and Board of Studies for their approval.

I extend thanks in anticipation.

Enclosures: as mentioned above

Satyendra Singh
Principal

Seth G.B. Podar College
Nawalgarh - 333042

CC to:- For necessary information



1. The Secretary, University Grants Commission, New Delhi

SETH G. B. PODAR COLLEGE NAWALGARH, RAJASTHAN

(Pandit Deendayal Upadhyaya Shekhawati University, Sikar Rajsathan)

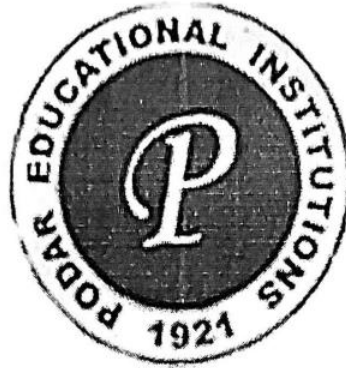

ORDINANCES FOR BACHELOR OF VOCATION

PART I (Semester I & II)- DIPLOMA
PART II (Semester III & IV)- ADVANCE DIPLOMA
PART III (Semester V & VI) -BACHELOR

Under
Choice Based Credit system
Scheme of
B. Voc.

Dr. Ravindra Goswami
H.O.D. & Assistant Professor
Department of Botany
Seth G. B. Podar College Nawalgarh, Rajasthan

(UGC under National Skill Quality Framework)

ORDINANCE FOR THE BACHELOR OF VOCATION

Bachelor of Vocation (B. Voc.) is launched under the scheme of University Grants Commission on skill development based higher education leading to Bachelor of Vocation (B. Voc.) Degree with multiple exits as Diploma/Advanced Diploma under the National Skill Qualification framework. The B.Voc. programme incorporate specific job roles and their National Occupational Standards along broad based general education. This course has been started In order to make education relevant and to create 'industry fit' skilled workforce,

B. Voc. programme has been designed as per National Skill Qualification Framework emphasizing on skill based education.

1. IMPORTANT TERMINOLOGY/ CONCEPTS RELATED TO THE COURSE

1.1 National Skills Qualification Framework (NSQF): B. Voc. Programme has been designed as per National Skill Qualification Framework (NSQF) emphasizing on skill based education. The National Skills Qualification Framework organizes qualifications according to a series of levels of knowledge, skills and aptitudes. It is a nationally integrated education and competency based skill framework that will provide horizontal and vertical mobility within vocational programme. There are four levels of NSQF in the B.Voc. programme such as Level 4 is certificate, Level 5 is Diploma, Level 6 is Advanced Diploma and Level 7 is B.Voc. Degree. This will enable a person to acquire desired competency levels, transit to job market and an opportune time return for acquiring additional skills to further upgrade their competencies. The NSQF is anchored at the National Skill Development Agency (NSDA) and is being implemented through the National Skills Qualifications Committee (NSQC)

1.2 National Skill Development Corporation India (NSDC): NSDC was set up as part of a national skill development mission to fulfil the growing need in India for skilled manpower across sectors and narrow the existing gap between the demand and supply of skills. NSDC has various Sector Skill Councils

1.3 Sector Skill Council (SSC): One of the mandates of Sector Skill Councils is to develop National Occupational Standards (NOSs) for various job roles in their respective industries. SSC embeds the competencies required for specific job roles in the higher education system for creating employable graduates

1.4 ASCI: Agriculture Sector Council of India—widely known as Agriculture based Sector Skill Council. Its one of the main function is to assess the students as accordance with NSQF for Qualification Pack/National Occupational Standards .

1.5 National Occupational Standards (NOS): National Occupational Standards (NOS) are national standards that specify the standard of performance an individual must achieve when carrying out a function in the workplace, together with the knowledge and understanding they need to meet that standard consistently. Essentially NOS are benchmarks of good practice. National Occupational Standards (NOS) or Occupational Standards (OS) defines one key function in a job role. These Occupational Standards are combined to a set, which is called Qualification Pack (QP).

1.6 Qualification Pack (QP): Qualification Pack certifies a person for a specific job role. Each Qualification Pack also contains NSQF Level. These packs are marked with a NSQF level, such as level 4,5,6 and 7. The Qualification Packs help in both the creation of curriculum and assessments.

1.7 Skill Development Component: Skill component of the programme /course is employment oriented. The skilled development component curriculum is aligned to Qualification Packs (QPs) / National Occupational Standards (NOSs) of selected job role(s) within the industry sector(s) and it will enable the students to meet the learning outcomes specified in the NOSs.

Dr. Lavindra Goswami
J.O.D. & Assistant Professor
Department of Botany
Soh. G. B. Pader College Newalpath, Rajasthan

1.8 General Education Component: The general education component includes the course(s) which are supportive to core trade in addition to soft skills, IT skills, and language proficiency and literature. It emphasizes on holistic development.

1.9 Credit Based Semester System (CBSS): Under the CBSS, the requirement for awarding a degree or diploma or certificate is prescribed in terms of number of credits to be completed by the students.

1.10 Credit(C): A unit by which the course work is measured. It determines the number of hours of instructions required per week. One credit is equivalent to one hour of teaching (lecture or tutorial) or two hours of practical work/field work per week. Accordingly, one Credit would mean equivalent of 14-15 periods of 60 minutes each or 28 – 30 hrs of workshops / labs.

1.11 Grade Point (G): It is a numerical weight allotted to each letter grade on a 10 point scale.

1.12 Credit Point (CP): The numerical value obtained by multiplying the grade point (GP) by the no. of credit(C) of the respective course i.e. $CP = G \times C$.

1.13 Semester Grade point Average (SGPA): It is a measure of performance of work done in a semester. The SGPA is the ratio of sum of the product of the number of credits with the grade points scored by a student in all the course components taken by a student

and the sum of the number of credits of all the courses undergone by a student in a semester, *i.e.*

$$SGPA (S_i) = \frac{\sum(C_i \times G_i)}{\sum C_i}$$

where 'C_i' is the number of credits of the ith course component and 'G_i' is the grade point scored by the student in the ith course component.

1.14 Cumulative Grade Point Average (CGPA): It is a measure of overall cumulative performance of a student over all semesters. The CGPA is also calculated in the same manner taking into account all the courses undergone by a student over all the semesters of a programme, *i.e.*

$$CGPA = \frac{\sum(C_i \times S_i)}{\sum C_i}$$

where 'S_i' is the SGPA of the 'i'th semester and C_i is the total number of credits in that semester. The SGPA and CGPA shall be rounded off to 2 decimal points and reported in the transcripts.

1.15 Letter Grade: It is an index of the performance of students in a said course. Grades are denoted by letters O, A+, A, B+, B, C, P, F and Ab

2. LEVELS OF AWARD

The certification levels shall lead to Diploma/Advanced Diploma/B.Voc. Degree in Dairy Technology

AWARD	DURATION	Core Level corresponding NSQF Level
CERTIFICATE	6 MONTHS	4
DIPLOMA	1 YEAR	5
ADVANCED DIPLOMA	2 YEAR	6
B. VOC. DEGREE	3 YEAR	7

3. NSQF LEVELS:

NSQF LEVEL	SKILL COMPONENT CREDITS	GENERAL EDUCATION CREDITS	NORMAL CALENDAR DURATION	EXIT /AWARDS POINT
Year 1	36	24	Two Semesters	Diploma
Year 2	36	24	Two Semesters	Advanced Diploma
Year 3	36	24	Two Semesters	Degree
Total	108	72	Six Semester	

Dr. Anura Goswami
Assistant Professor
Department of Dairy
Technology
College of Dairy Technology

4. **GUIDELINES FOR CREDIT CALCULATIONS:** The following formula should be used for conversion of time into credit hours.
- I. One Credit would mean equivalent of 15 periods of 60 minutes each for theory, workshops/ labs and tutorials.
 - II. For internship/field work, the credit weightage for equivalent hours shall be 50% of that for lectures/workshops.
 - III. For self-learning, based on e-content or otherwise, the credit weightage for equivalent hours of study should be 50% or less of that for lectures/workshops.

5. **ELIGIBILITY FOR ADMISSION IN B.VOC.**

A candidate will be eligible to join 1st semester of B.Voc Dairy Technology course, if he/she has passed 10+2 examination (any stream/ Arts/Science/Commerce) or 10+2 vocational stream related to Dairy Technology of recognized Board/ university or any other examination recognized as equivalent thereto without reappear.

5.1 The course of study of B.Voc. shall be divided in to six semesters and university examination will be held at the end of every semester in the months of November/December (for semester I, III & V) and May/June (for semester II, IV & VI) or as fixed by the Vice Chancellor.

5.2 Semester examination will be open to regular candidates who have been on the rolls of a college affiliated to this University and meet the attendance and other requirements. Subject to fulfillment of requirement of House examinations, the attendance requirement and these ordinances there will be no condition of passing papers for promotion from odd semester to even semester in an Academic Session.

5.3 To qualify for admission to 3rd semester of the Course, the candidate must have passed 50% of total papers of the two semesters of the 1st year. In case, the result of 2nd Semester is not declared at the time of admission to 3rd Semester, the student may be admitted provisionally and will be allowed to take examination of 3rd semester if he/she has passed in 50 % of the total papers of first year (i.e. 1st and 2nd Semesters). Similarly, to qualify for admission to 5th semester of the course, the student may be admitted provisionally if the result of previous semester has not been declared and will be allowed to take examination of 5th semester, if he/she has passed 50% of the total papers of previous semesters.

5.4 A candidate placed under reappear in any paper, will be allowed two chances to clear the reappear, which should be availed within consecutive two years/chances i.e. to pass in a paper the candidate will have a total of three chances, one as regular student and two as reappear candidate. The examination of reappear papers of odd semesters will be held with regular examination of the odd semester and reappear examination of the even semester will be held with regular examination of even semester. But if a candidate is placed under reappear in the last semester of the course, he will be provided chance to pass the reappear with the examination of the next semester, provided his reappear of lower semester does not go beyond next semester.

6. **ACADEMIC EQUIVALENCE:**

6.1. Bachelor of Vocation (B. Voc.), a Bachelor level degree specified by UGC under section 22(3) of UGC Act, 1956 and notified in official Gazette of India dated 19th January, 2013 is recognized at par with the other Bachelor level degrees for competitive exams conducted by Union/State Public Service Commission, Staff Selection Commission or other such bodies where the eligibility criteria is "Bachelor Degree in any discipline".

6.2. Students with B.Voc. Degree are considered eligible for the trans-disciplinary vertical mobility into such courses where entry qualification is a Bachelor Degree without specific requirement in a particular discipline.

Dr. Ravindra Goswami
H.O.D. & Assistant Professor
Department of Botany
Geth G. B. Poddar College Newalgaoh, Rajasthan

6.3. Students qualifying B.Voc. in Dairy Technology can take admission in M.Sc.(Food Technology/Dairy Technology/Microbial Food Technology etc.)

7. ATTENDANCE AND UNIVERSITY EXAMINATION SYSTEM

7.1 Every candidate will be required to attend a minimum of 75% lectures delivered to that class in each paper as well as 75% of the laboratory work, seminars etc. separately. Provided that a deficiency in attendance may be condoned for special reasons as per the relevant ordinances on the subject.

7.2 To be eligible to appear in the semester examination, a candidate must have obtained in the house examination at least 25% marks in each paper, 25% marks in the aggregate of all subjects of the semester. The Principal at his discretion may allow a special test to a candidate who could not appear in the House examination owing to unavoidable reason, or fails to secure the minimum marks as prescribed above.

7.3 Amount of examination fee to be paid by a candidate for each semester will be as fixed by the University from time to time.

7.4. Applications for admission to the examination will be made on the prescribed form attested by the competent authority as per University rules.

7.5. The Candidate will also be entitled to grace marks as admissible under the ordinances, relating to the '**Grace Marks.**'

7.6. The minimum number of marks required to pass the examination in each Part shall be 35% in each subject of theory paper, practical examination and internal assessment separately.

7.7 Except Qualification pack/Skill Component other papers shall be taken by university. Result of skill component shall be communicated by respective college after evaluation by respective sector skill councils to university in time for final awarding Diploma/Advance Diploma/Degree.

8. INTERNAL ASSESSMENT AND ITS COMPONENTS:

Internal assessment, in each subject, shall be 20% of the total marks in each paper and shall be uniformly applicable to all the Subjects/Papers. The four Components for Internal Assessment shall be as follows (to be divided equally, as per the credit of the paper):

(i)	Attendance: The students with 85%-100% attendance will be given full attendance marks. Whereas students with 80%-84.9% attendance shall be given 80% marks of attendance and students with 75%-80% shall get 60% of attendance marks.	20%	% of the Total Marks of the internal Assessment
(ii)	Written Assignment/Project :	40%	
(iii)	Two Mid-Semester Tests/Internal Examination (Average of both Mid-Semester Tests/Internal Examination)	40%	

(c) In each Theory Paper 20% of the total marks are assigned to the internal assessment and 80% marks

to the University examination.

The **medium of instruction** and examination will be English/Hindi except for the language subjects

Dr. Ravindra Goswami
M.D. & Assistant Professor
Department of Botany
Govt. B. Pader College, Nawalgarh, Rajasthan

whose medium of instruction and examination will be that of the language subject.

9. A CANDIDATE WILL BE ALLOWED TO JOIN:

- (i) First Semester: Provided that he/she has qualified 10+2 examination or equivalent without reappear.
- (ii) Second Semester: Provided that he/she has undergone a regular course of studies of first semester.
- (iii) Third Semester: Provided that he/she has undergone a regular course of studies of First and Second semesters as provided under the regulations in sequential order and fulfils the conditions as laid in ordinance 5(a) & 5(b).
- (iv) Fourth Semester: Provided that he/she has undergone a regular course of studies of First, Second and Third semesters as provided under the regulations in sequential order and has passed the First Semester Examination as a whole, and fulfils the conditions as laid in ordinance 5(a) & 5(b).
- (v) Fifth Semester: Provided that he/she has undergone a regular course of studies of First, Second, Third and Fourth semesters as provided under the regulations in sequential order and fulfils the conditions as laid in ordinance 5(a) & 5(b).
- (vi) Sixth Semester: Provided that he/she has undergone a regular course of studies of First, Second, Third, Fourth and Fifth semesters as provided under the regulations in sequential order and has passed 50 % of the total papers of previous semesters and fulfils the other conditions as laid in ordinances.

*Evaluation of third year (fifth and sixth semester) shall be conducted only on the basis of general component part as there are no qualification packs for third year available till date.

10. Three weeks after the termination of examination or as soon as thereafter possible, the Registrar will publish the result of the candidates. Each candidate shall receive a certificate indicating details of marks obtained in each examination.

11. **GRADES AND GRADE POINTS** The Successful candidates shall be classified on the basis of 10-point grade following letter grades

Letter Grade	Grade Points
O (Outstanding) 10	10
A+ (Excellent) 9	9
A (Very Good) 8	8
B+ (Good) 7	7
B (Above Average) 6	6
C (Average) 5	5
P (Pass) 4	4
F (Fail) 0	0

- 12 A candidate who has passed B.Voc. examination from this University shall have one chance within a period of two years after passing the examination to improve division or 55% marks. Improvement shall be allowed in not more than three theory papers offered in each semester. However, previous marks of Practical/Project will be carried forward in the paper(s) in which he/she appears for improvement and be awarded one percent of grace marks on the basis of given papers, out of the papers taken up, the candidate will be given benefit of increase in marks, where the marks have increased in paper/papers.

13. Re-evaluation of scripts shall be admissible in B.Voc.. Examination Semester I, II, III, IV, V, VI examination except practical examination. The re evaluation shall be allowed in not more than two theory papers provided candidate has scored not less than 25% marks in the relevant paper. The candidate shall

Dr. Savindra Goswami
D.O. & Assistant Professor
Department of Botany
M. J. Somaiya College, Marolgia, Rajasthan

submit his/her application on specified form along with prescribed fee, for re-evaluation within 14 days from the date of declaration of the result.

14. **DISTRIBUTION OF MARKS FOR PRACTICALS** : Each practical paper consists of 45 marks in each semester .It includes: 25 marks for Performance ; 10 marks for write-up ;10 marks for file and viva voce
15. **Industrial Visit is mandatory** as part of the curriculum with the submission of report to Head of the department .Total marks assigned are 20. Evaluation criteria will include 10 marks for report ;5 marks for presentation; 5 marks for viva voce
16. **COMPULSORY TRAINING:** Training of one month in relevant sector for completion of Diploma and 1and half month for completion of advance Diploma is mandatory. Report based on satisfactory/unsatisfactory shall be sent by Head of the Department countersigned by Principal.
17. **INDUSTRIAL/INSTITUTIONAL PROJECT** A candidate shall have to undertake an Industrial/Institutional Project in Final year (6thSemester). The project report shall be presented in front of external examiner, Supervisor & two faculty members (nominated by the principal). The report must be signed by concerned authority. Project work will be of 200 marks based on three categories: 100 marks Performance and Practical ; 50 marks Project Report; 50 marks Viva Voce

Dr. S.indra Goswami
Assistant Professor
Department of Botany
Jawahar College, Mandigarh, Rajasthan

**SETH G. B. PODAR COLLEGE NAWALGARH,
RAJASTHAN**

(Pandit Deendayal Upadhyaya Shekhawati University, Sikar Rajsathan)



Course Structure

B.Voc. in Ecotourism and Conservation of cultural Heritage

B.Voc. In Eco-Tourism and Conservation of Cultural Heritage

Dr. Anandra Goswami
O.D. & Assistant Professor
Department of Botany
Seth G. B. Podar College, Nawalgarh, Rajasthan

DIPLOMA/ADVANCE DIPLOMA IN ECOTOURISM AND CONSERVATION OF CULTURAL HERITAGE

RATIONALE

The aim of the Diploma Programme in Eco-Tourism and Conservation of cultural Heritage emphasizes on nature based tourism and analyses the history, concepts, principles, marketing, planning and management of Ecotourism activities in eco-tourism centers. It also highlights the development of ecological and cultural sustainability, education interpretation and economic benefits at the local level. This module will provide the student with an understanding of the theory and in managing the eco-tourism resources effectively. And promote Cultural Heritage as well as conservation techniques to protect our glorious heritage as well.

AVAILABILITY OF INDUSTRY & MARKET SURVEY FOR JOB OPPORTUNITIES

The job opportunities for the pass outs of this Programme include: Tourism development specialist, sustainable tourism business development manager, sustainable development consultancy, ecosystem management and development, ecosystem management and development officer, tourism and human resources advisor Conservation scientist, nature center research technician, biodiversity specialist, Gallery attendant/Assistant Conservator Exhibition Organiser.

Dr. Anandra Goswami
A.D. & Assistant Professor
Department of Botany
Seth G. B. Podar College, Nawalgarh, Rajasthan

**PROGRAM STRUCTURE DIPLOMA/ADVANCE DIPLOMA/B.VOC. IN ECOTOURISM
AND CONSERVATION OF CULTURAL HERITAGE**

SEMESTER	PAPER CODE	TITLE	Diploma/ Advance Diploma Course		CREDIT	NSQF LEVEL	JOB ROLES AS PER SSC
			INTERNAL	EXTERNAL			
I GEC	ECCHB101G	COMMUNICATION SKILLS & PERSONALITY DEVELOPMENT	20	80	6	4-CERTIFICATE	Tourism Planner
	ECCHB102G	ENVIRONMENTAL STUDIES	20	80	6		
I SEC	ECCHB101S	INTRODUCTION TO HERITAGE AND TOURISM	20	80	4		
	ECCHB102S	ECOTOURISM	20	80	4		
	ECCHB103S	TOURISM PLANNING, POLICY AND DEVELOPMENT	20	80	4		
	ECCHB104S	PRACTICALS	50	100	6		
II GEC	ECCHB201G	BASICS OF COMPUTERS	20	80	6		
	ECCHB202G	BASICS OF BIOSTATISTICS	20	80	6		
II SEC	ECCHB201S	GEOGRAPHY, HERITAGE AND TOURISM	20	80	4	5-DIPLOMA	
	ECCHB202S	MANAGEMENT FUNCTION AND PRACTICES IN TOURISM	20	80	4		
	ECCHB203S	INTRODUCTION TO HERITAGE OBJECT	20	80	4		
	ECCHB204S	PRACTICAL	50	100	6		
III GEC	ECCHB301G	BASIC ANALYTICAL CHEMISTRY	20	80	6		
	ECCHB302G	RENEWABLE AND GREEN TECHNOLOGY	20	80	6		
III SEC	ECCHB301S	TOURISM MARKETING AND COMMUNICATION	20	80	4		
	ECCHB302S	ENVIRONMENT CONSERVATION OF NATURAL RESOURCES AND ECOTOURISM	20	80	4		
	ECCHB303S	TOURISM PRODUCTS AND OPERATION	20	80	4		
	ECCHB304S	PRACTICALS/INTERSHIP	50	100	6		
IV GEC	ECCHB401G	COMPUTER IN HERITAGE & TOURISM	20	80	6	6 ADVANCE DIPLOMA	TOURIST GUIDE/ COMMUNICATOR
	ECCHB402G	ENTREPRENEURSHIP DEVELOPMENT	20	80	6		
IV SEC	ECCHB401S	EMERGING TRENDS IN ECOTOURISM	20	80	4		
	ECCHB402S	TOURISM INDUSTRY	20	80	4		ADVANCE

		&ORGANIZATION					DIPLOMA
	ECCHB403S	TOURISM SITES AND ATTRACTION	20	80	4		
	ECCHB404S	PRACTICALS/ INTERNSHIP	50	100	6		
V GEC	ECCHB501G-	COMPETENCY PLANNING, MAPPING AND FINANCIAL ENGINEERING	20	80	6		
	ECCHB502G	INTELLECTUAL PROPERTY RIGHTS	20	80	6		
V SEC	ECCHB501S	TANGIBLE AND INTANGIBLE HERITAGE	20	80	4		
	ECCHB502S:	LITERACY HERITAGE OF ANCIENT INDIA	20	80	4		
	ECCHB503S	SURVEY OF ANCIENT INDIAN ART	20	80	4		
	ECCHB504S	PROJECT/INDUSTRY TRAINING	50	100	6		
VI GEC	ECCHB601G	INDUSTRIAL PSYCHOLOGY	20	80	6	7- BACHELOR (B.VOC.)	CONSERVATOR/ TOUR EXPERT
	ECCHB602G	PRODUCTS AND ADVERTISEMENT MANAGEMENT	20	80	6		
VI SEC	ECCHB601S	HERITAGE APPLICATION OF TOURISM IN RAJASTHAN	20	80	4		
	ECCHB602S	ARCHIVAL SOURCES, MANUSCRIPTS AND VANSHAVALI	20	80	4		
	ECCHB603S	INTEGRATED PEST MANAGEMENT, RISK & DISASTER MANAGEMENT	50	100	4		
	ECCHB604S	PROJECT REPORT ON THE BASIS OF INDUSTRIAL TRAINING INTERNSHIP/SURVEY	50	150	6		

Dr. 
 Anita Goswami
 Assistant Professor
 Department of Botany
 Seth G. B. Podar College, Nawalgarh, Rajasthan

**SETH G. B. PODAR COLLEGE NAWALGARH,
RAJASTHAN**
(Pandit Deendayal Upadhyaya Shekhawati University, Sikar Rajsathan)



Course Structure

B.Voc. IN NUTRITION & HEALTH CARE SCIENCES

RATIONALE:

The duration of Bachelor of Vocational Degree Programme shall extend over six semesters(three academic years) of 18 weeks each including End Semester Examination with multiple exit and entry. This would enable the student to seek employment after any level of award and join back as and when feasible to upgrade her / his qualification / skill competency either to move higher in her / his job or in the higher educational system. The students will have the option to exit with a Certificate, Diploma or Advanced Diploma after acquiring requisite no of credits. One credit is equivalent to one hour of teaching (lecture or tutorial) or two hours of practical work/field work per week (One credit would mean equivalent of 14-15 periods of 60minutes each or 28 – 30 hrs of workshops / labs).For internship / field work, the credit weightage for equivalent hours shall be 50% of that for lectures / tutorials.For self-learning,based on e-content or otherwise, the credit weightage for equivalent hours of study shall be 50% of that for lectures / tutorials.

AVAILABILITY OF INDUSTRY & MARKET SURVEY FOR JOB OPPORTUNITIES

- The job opportunities for the pass outs of this Programme include: Diet Assistant (HSS/Q5201)/ Medical Lab helper/Yoga instructor, General Duty Assistant (HSS/Q5101) Medical /Health Advisor (Diploma Level)General Nutritionist (Diploma Level)/ Laboratory Technician, Geriatric Aide (HSS/Q6001) Home Health Aider (HSS/Q510) General Duty Assistant (HSS/Q5101) / Assistant Dietician, Patient Relation associate (HSS/Q6102) Assistant duty manager(HSS/Q6103) Duty manager (HSS/Q6104) Assistant Catering Manager, Clinical Nutritionists In Hospitals/Clinics/Clinical Research Organizations Catering Manager, Dietitian, Diabetic Educator ,Diet Assistant ,Nutritionist in Food Industry

Dr. Anshu Goswami
Assistant Professor
Department of Botany
Seth G.B. Podar College, Nawalgarh, Rajasthan

Bachelor of Vocation in Nutrition and Health Care Science

Semester	Paper Code	Title	Marks			NSQF Level	Job roles as per SSC
			Internal	External	CRE DITS		
I GEC	NHCSB101G	COMMUNICATION SKILLS & PERSONALITY DEVELOPMENT	20	80	6	4- CERTIFICATE	Diet Assistant (HSS/Q5201) / Medical Lab helper
	NHCSB102G	HUMAN BIOLOGY	20	80	6		
I SEC	NHCSB101S	FOOD & BASIC NUTRITION	20	80	4		(Certificate Level)
	NHCSB102S	INDIAN TRADITIONAL FOODS & AYURVEDIC NUTRITION	20	80	4		
	NHCSB104S	LABORATORY METHODS IN HEALTH SCIENCES	20	80	4		
	NHCSB105S	PRACTICAL,	50	100	6		
II GEC	NHCSB201G	HEALTH AND HYGIENE	20	80	6	5- DIPLOMA	General Duty Assistant (HSS/Q5101) Medical /Health Advisor General Nutritionist (Diploma Level)/ Laboratory Technician
	NHCSB202G	INTRODUCTION TO HUMAN PSYCHOLOGY	20	80	6		
II SEC	NHCSB201S	NUTRITION FOR HEALTH AND FITNESS	20	80	4		DIPLOMA
	NHCSB202S	HOSPITAL ADMINISTRATION SKILLS	20	80	4		
	NHCSB203S	BASIC DIETETICS, TECHNIQUES AND PATIENT COUNSELING	20	80	4		
	NHCSB204S	PRACTICAL/ INTERNSHIP	50	100	6		
III GEC	NHCSB301G	DISASTER MANAGEMENT	20	80	6		
	NHCSB302G	PLANT BASED NUTRITION	20	80	6		
III SEC	NHCSB301S	FOOD PRODUCT DEVELOPMENT AND EVALUATION	20	80	4		
	NHCSB302S	NUTRITION THROUGH LIFE CYCLE	20	80	4		
	NHCSB303S	FOOD MICROBIOLOGY	20	80	4		
	NHCSB304S	PRACTICAL	50	100	6		
IV GEC	NHCSB401G	PHYSIOLOGY & BIOCHEMISTRY	20	80	6	6-ADVANCE DIPLOMA	Geriatric Aide (HSS/Q6001) Home Health Aider (HSS/Q510) General Duty Assistant (HSS/Q5101) / Yoga instructor/ Assistant
	NHCSB402G	YOGA ,NATURE CURE & HEALTH	20	80	6		
IV SEC	NHCSB401S	ANALYTICAL INSTRUMENTATION IN FOOD & NUTRITION	20	80	4		
	NHCSB402S	NUTRI ADDITIVES, NUTRACEUTICALS & PHYTOCOMPOUNDS	20	80	4		
	NHCSB403S	NUTRITIONAL QUALITY ASSURANCE & FOOD	20	80	4		

V GEC	NHCSB404S	PACKAGING PRACTICAL & MINOR INTERNSHIP / TRAINING	50	100	6	Dietician ADVANCE DIPLOMA
	NHCSB501G	QUALITATIVE ANALYSIS & COMPUTER APPLICATION	20	80	6	
	NHCSB502G	INTELLECTUAL PROPERTY RIGHTS	20	80	6	
V SEC	NHCSB501S	INTRODUCTION TO HUMAN DISEASES	20	80	4	
	NHCSB502S:	THERAPEUTIC NUTRITION & DIETETICS	20	80	4	
	NHCSB503S	NUTRITION COUNSELLING AND SUPPORT SYSTEMS	20	80	4	
	NHCSB504S	PRACTICAL	50	100	6	
VI GEC	NHCSB601G	PRINCIPLES OF BIostatISTICS	20	80	6	7- Bachelor (B.Voc.) Clinical Nutritionists In Hospitals/ Clinics/ Clinical Research Organization s Catering Manager, Dietitian, Diet Assistant, Nutritionist in Food Industry
	NHCSB602G	CONCEPT OF ENTREPRENEURSHIP	20	80	6	
VI SEC	NHCSB601S	FOOD FORTIFICATION & PROCESSING	20	80	4	
	NHCSB602S	INSTITUTIONAL FOOD ADMINISTRATION	20	80	4	
	NHCSB603S	PRACTICAL	50	100	4	
	NHCSB604S	MAJOR PROJECT/TRAINING/ INTERNSHIP	50	150	6	

Dr. Lavindra Goswami
 ...O.D. & Assistant Professor
 Department of Botany
 Seth G. B. Podar College Nawalgarh, Rajasthan

Details of Counselling Cell and activities under this Cell

(Webinar, Seminar etc.)



www.podarcollege.com

PODAR COLLEGE

Welcomes You

dm

Principal

Seth G.B. Podar College
- Nawalgarh - 333042



पोदार कॉलेज में प्रवेश प्रक्रिया हेतु परामर्श केन्द्र

दिनांक 29 - 07 -2021

दी आनन्दील पोदार ट्रस्ट के अन्तर्गत संचालित पोदार कॉलेज में दिनांक 29 जुलाई 2021 को परामर्श केन्द्र का शुभारम्भ हुआ । पोदार कॉलेज प्रबंधन ने पोदार कॉलेज में विद्यार्थियों के प्रवेश कार्य में सहायतार्थ कमरा नं. 06 में विद्यार्थी परामर्श केन्द्र का शुभारम्भ किया गया ।

जिसका विधिवत् उद्घाटन दी आनन्दीलाल पोदार ट्रस्ट के निदेशक श्री एम. डी शानभाग ने किया । इस दौरान कॉलेज के प्राचार्य डॉ. सत्येन्द्र सिंह एवं उप प्राचार्य डॉ. विनोद कुमार सैनी उपस्थित रहे जिन्होंने परामर्श केन्द्र में दायित्व निर्वहन करने वाले स्टॉफ सदस्यों को विद्यार्थियों को प्रेरित करने के लिए प्रोत्साहित किया । प्रवेश चाहने वाले विद्यार्थियों को विषय चुनने व उसके मार्ग दर्शन हेतु विषय विशेषज्ञ आचार्यों को नियुक्त किया गया गया । परामर्श केन्द्र के दायित्व निर्वाह की जिम्मेदारी हिन्दी विभाग के विभागाध्यक्ष डॉ. अनिल कुमार शर्मा एवं लेखा विभाग के सहायक आचार्य श्री शुभम् शर्मा प्रदान की गयी ।

कॉलेज प्रबंधन एवं हॉस्टल से सम्बन्धित समस्त जानकारी भी विद्यार्थियों को प्रदान की जायेगी यह निश्चित किया गया । विद्यार्थियों को एन.सी.सी. एवं एन.एस.एस. से सम्बन्धित जानकारी ले. कमलेश कुमार एवं प्रो. शान्तिलाल जोशी प्रदान करेंगे । विद्यार्थियों की प्रवेश प्रक्रिया अब भी निरन्तर प्रगति पर है ।

Principal
Seth G.B. Podar College
Nawalgarh - 333042

PODAR EDUCATIONAL INSTITUTIONS

G. B. PODAR COLLEGE, NAWALGARH

(Run by The Anandilal Podar Trust, Nawalgarh)



77
University Merits
In the last
10 years

Our University Meritorious Students 2016-17



Admissions Open... 2021-22

Separate Classes for English & Hindi Medium

U.G. and P.A. Courses in the Faculty of Letters, Commerce & Arts

B.A. Bachelor of Business Administration
B.Com. Bachelor of Commerce

Podar Educational Institutions, Nawalgarh

Mob. : 6376173950, 8948130850, 8005707723
Ph. : 01594-222030

www.podarcollege.com
Email: principal@podarcollege.com

PODAR COLLEGE, NAWALGARH

Admission Merit List for the year 2021-22 after all Podar Prorogues

FEE CONCESSION

S. No.	Students	For Girl Students		For other Categories	
		Percentage	Amount	Percentage	Amount
1	0-10%	10%	1000	10%	1000
2	11-20%	20%	2000	20%	2000
3	21-30%	30%	3000	30%	3000
4	31-40%	40%	4000	40%	4000
5	41-50%	50%	5000	50%	5000
6	51-60%	60%	6000	60%	6000
7	61-70%	70%	7000	70%	7000
8	71-80%	80%	8000	80%	8000
9	81-90%	90%	9000	90%	9000
10	91-100%	100%	10000	100%	10000

Rank of UPT
Date

For other categories: 1. SC/ST, 2. OBC, 3. PwD, 4. Other

PODAR COLLEGE, NAWALGARH

Admission Merit List for the year 2021-22 after all Podar Prorogues

For other categories: 1. SC/ST, 2. OBC, 3. PwD, 4. Other

Ans
Principal
Sethi G. B. Podar College
Nawalgarh - 332022

परामर्श केन्द्र खोलने के उद्देश्य

पोदार कॉलेज प्रबन्धन ने विद्यार्थियों के मार्ग दर्शन हेतु परामर्श केन्द्र का विधिवत उद्घाटन किया । जिसमें विषय विशेषज्ञों को नियुक्त कर विद्यार्थियों की अनेक शंकाओं का निवारण करने का उद्देश्य रखा गया । कॉलेज में प्रवेश प्राप्त करने वाले विद्यार्थियों को एक ही स्थान पर सम्पूर्ण जानकारी प्राप्त हो सके यही परामर्श केन्द्र का उद्देश्य रखा गया ।

परामर्श केन्द्र के माध्यम से पोदार महाविद्यालय प्रांगण एवं उससे सम्बन्धित जानकारी भी आगन्तुक अतिथियों और विद्यार्थियों को प्राप्त हो सके। परामर्श केन्द्र में पोदार शिक्षण संस्थाओं की सम्पूर्ण जानकारी व उसके प्रवेश प्रक्रिया को भी सहजता से विद्यार्थियों को समझना भी उद्देश्य रहा है।

कॉलेज की प्रयोगशालाएँ, सुविधाएँ एवं अन्य जानकारी के लिए आगन्तुक विद्यार्थियों को विजिट कराने का उद्देश्य भी है जिससे विद्यार्थी संस्था के प्रति आश्वस्त होकर प्रवेश लेकर अध्ययन कर सके।



Principal
Seth G.B. Podar College
Nawalgarh - 333042



Department of Computer Science and Management
Seth G B Podar College, Nawalgarh

Webinar Report

Date	:	05 th February 2021
Time	:	02:00 onwards
Webinar on	:	Google Meet App
Title	:	Education & Career Guidance
Key Note Speaker	:	Dr. J. P. Karwasara
Attended by	:	PIMS Faculty Members, BBA and BCA Students
Distribution	:	IQAC & Principal Office.

“Education & Career Guidance”

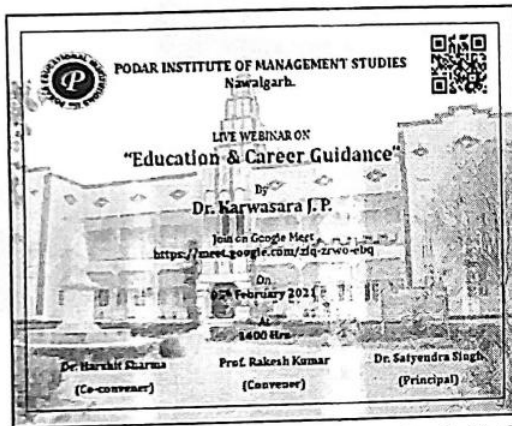

At beginning of the session, Prof. Rakesh Kumar (HoD, BCA) welcomed Dr. Karwasara for their scheduled lecture on “Education & Career Guidance”.

Our today’s webinar resource person **Dr. J. P. Karwasara** started his lecture by explaining “the value of education” in present scenario as well as “how proper guidance is required while choosing career options after (10+2).” Education is the process of facilitating learning, or the acquisition of

knowledge, skills, values, morals, beliefs, and habits. Educational methods include teaching, training, storytelling, discussion and directed research. Education frequently takes place under the guidance of educators; however learners can also educate themselves. Education can take place in formal or informal settings and any experience that has a formative effect on the way one thinks, feels, or acts may be considered educational.

He has described the importance of getting good education and how it helps in making students future. As he asked students to have futuristic approach and keep going with what they would like to pursue as their career. Explaining through various examples from Bhagwat Geeta, Ramayana and his own personal experience, Dr. Karwasara asked students to work hard and have a dream, where students can work upon.

At the end of the session, Dr. Harshit Sharma (Assistant Professor) thanked Dr. Karwasara for presenting a very fruitful and valuable session to the students of PIMS department.

Principal

Seth G.B. Podar College
Nawalgarh - 333042

Few glimpse of today's webinar:

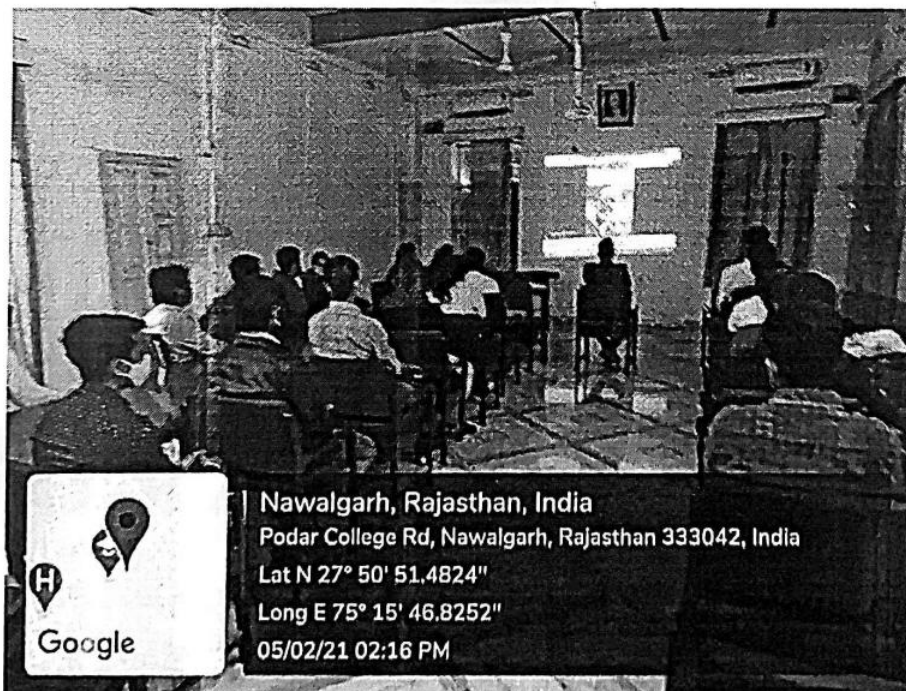
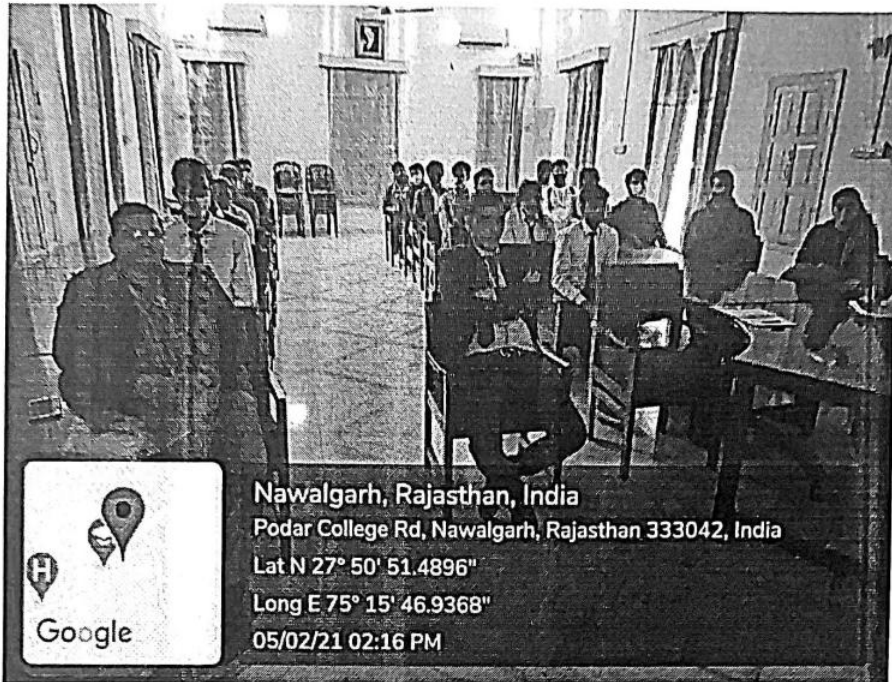

Principal
Seth G.B. Podar College
Nawalgarh - 333042

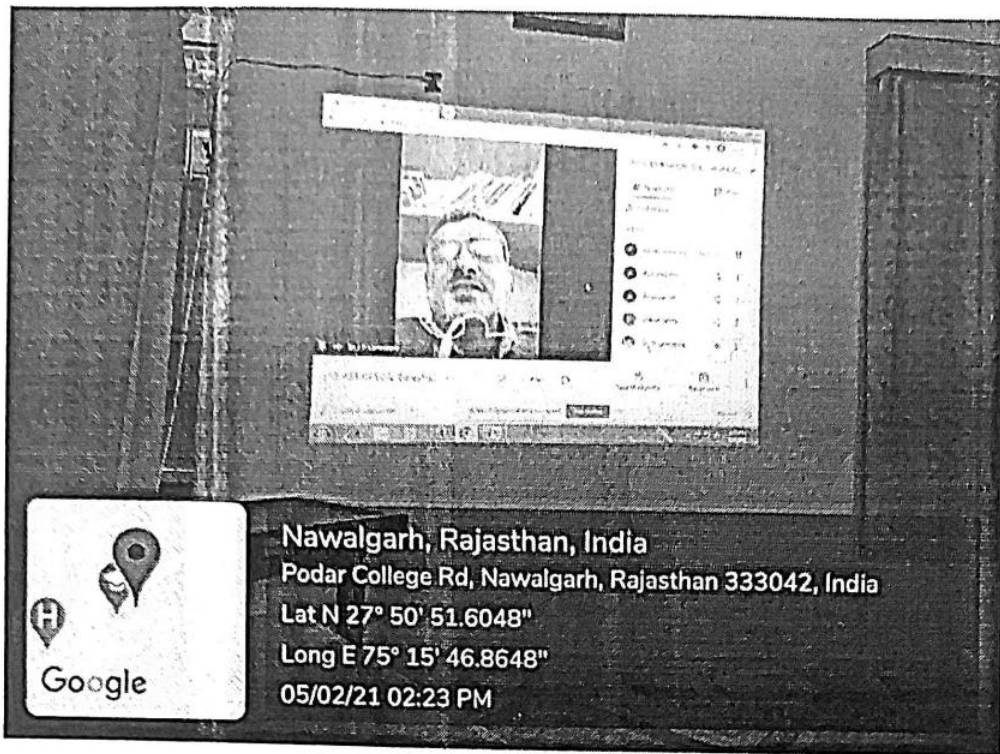

Nawalgarh, Rajasthan, India
Podar College Rd, Nawalgarh, Rajasthan 333042, India
Lat N 27° 50' 51.6048"
Long E 75° 15' 46.8648"
05/02/21 02:23 PM

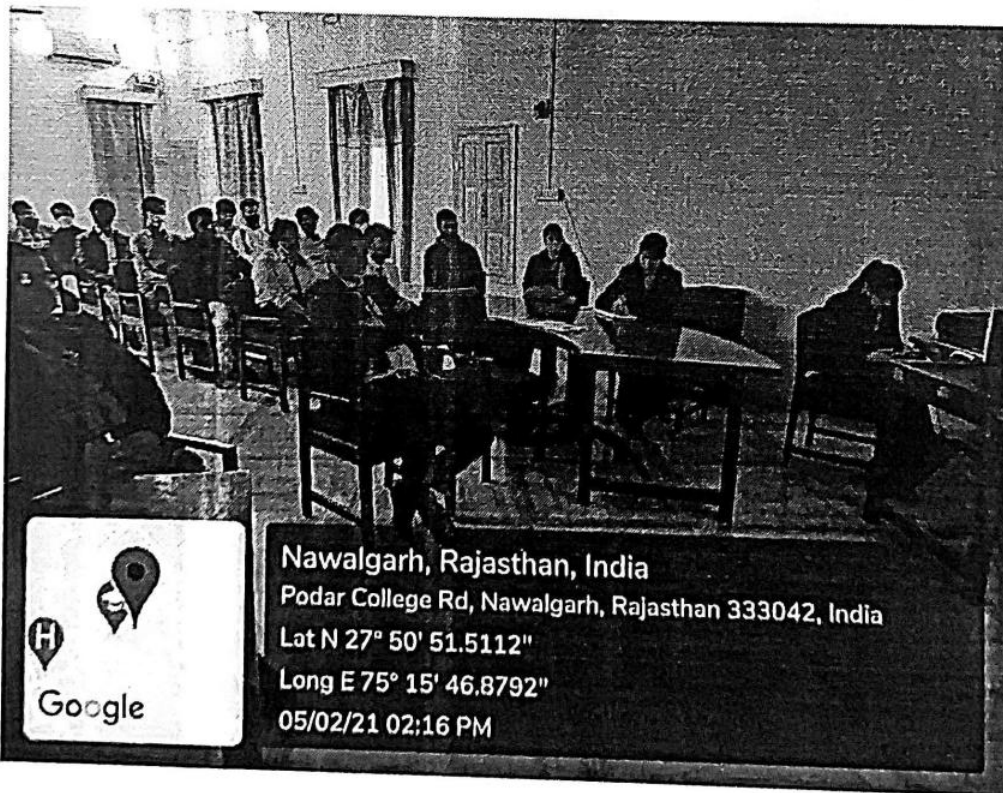

Nawalgarh, Rajasthan, India
Podar College Rd, Nawalgarh, Rajasthan 333042, India
Lat N 27° 50' 51.5112"
Long E 75° 15' 46.8792"
05/02/21 02:16 PM

Principal
Seth G.B. Podar College
Nawalgarh - 333042

कॅरियर गाइडेंस विषय पर हुई वेबीनार

नवलगढ़, कस्बे स्थित पोदार कॉलेज के पोदार इंस्टीट्यूट ऑफ मैनेजमेंट में एज्युकेशन एण्ड कॅरियर गाइडेंस विषय पर वेबीनार का आयोजन किया गया। वेबीनार के मुख्य वक्ता डॉ. जे.पी. कड़वासरा ने विद्यार्थियों को शिक्षा का वास्तविक अर्थ बताते हुए कॅरियर में आगे बढ़ने के लिए मार्गदर्शन किया। साथ ही विद्यार्थियों को अपने लक्ष्य और विजन को तय करके ही जीवन में आगे बढ़ने की

बात कही। वेबीनार में बी.बी.ए. व बी.सी.ए. के विद्यार्थियों ने भाग लिया। पोदार कॉलेज प्राचार्य डॉ. सत्येन्द्र सिंह व विभाग के विभागाध्यक्ष प्रो. राकेश महला सहित अन्य व्याख्याता मौजूद रहे। पोदार ट्रस्ट के चेयरमैन कान्तिकुमार आर. पोदार व ट्रस्टी वेदिका पोदार का मानना है कि ऐसी वेबीनार विद्यार्थियों को अपने कॅरियर के निर्माण में सहायक सिद्ध होगी।

Rajashan Patrika , Jhunjunu

पोदार कॉलेज में वेबिनार का आयोजन

न्यूज सर्विस/नवज्योति, नवलगढ़। कस्बे के पोदार कॉलेज नवलगढ़ में पोदार ट्रस्ट के चेयरमैन कान्तिकुमार आर. पोदार व ट्रस्टी वेदिका पोदार की प्रेरणा से पोदार इंस्टीट्यूट ऑफ मैनेजमेंट में एज्युकेशन एण्ड कॅरियर गाइडेंस विषय पर वेबीनार का आयोजन किया गया। जिसके मुख्य वक्ता डॉ. जे.पी. कड़वासरा ने विद्यार्थियों के शिक्षा का वास्तविक अर्थ बताते हुए कॅरियर में आगे बढ़ने के लिए मार्गदर्शन किया और साथ ही विद्यार्थियों को अपने लक्ष्य और विजन को तय करके ही जीवन में आगे बढ़ने के लिए प्रेरित किया। पोदार कॉलेज प्राचार्य डॉ. सत्येन्द्र सिंह एवं विभाग के विभागाध्यक्ष प्रो. राकेश महला सहित सभी व्याख्याता मौजूद रहे।

Principal

Seth G.B. Podar College
Nawalgarh - 333042



Department of Computer Science and Management
Seth G B Podar College, Nawalgarh

Report of Expert Lecture Conducted

Date	:	13 th March 2021
Time	:	01:00 PM onwards
Place	:	PIMS, Room No. 41
Resource Person	:	Mr. Hitesh Sharma working with TCS Ahmadabad
Organized by	:	PIMS Faculty
Present	:	Prof. Rakesh Kumar, Dr. Harshit Sharma, Prof. Madhu Saini, Prof. Anil Kumar Chotiya, Prof. Jyoti Khandelwal,
Participants	:	Students of BCA and BBA
Distribution	:	IQAC & Principal Office

Expert Lecture on “Career Counseling”

The objective of this guest lecture is to create awareness among the outgoing students on the steps for success in interviews. The Program was started with invocation followed by brief introduction about the resource person. The session started with the key points for preparation to a successful interview and practice. The suggestions given during lecture sessions are as follows:

- 1. Self-Evaluation**
- 2. Before the Interview**
 - a. Research the company
 - b. Practice interviews
 - c. Dress professionally
 - d. Arrive early
- 3. During the Interview**
 - a. First impressions (only in 30 seconds)

Principal

Seth G.B. Podar College
Nawalgarh - 333042

- b. Smile
 - c. Body Language
 - d. Speak clearly
 - e. Listen before answering
 - f. Give brief answers
 - g. Previous employers
 - h. Be truthful
 - i. Know your resume
 - j. Keep things at a professional level
4. After the Interview
- a. Back in touch
 - b. Get everyone's business card
 - c. Thank the interviewer

After this session guidance has been given for **Group Discussion**. The students have shown their interest in interacting with the resource person regarding the common interview questions and positive and negative point in G.D. The lecture sessions were very informative and highly interactive for our final year students. At the end, feedback was taken and the session ended up with vote of thanks delivered by Dr. Harshit Sharma.



Principal
Seth G.B. Podar College
Nawalgarh - 333042

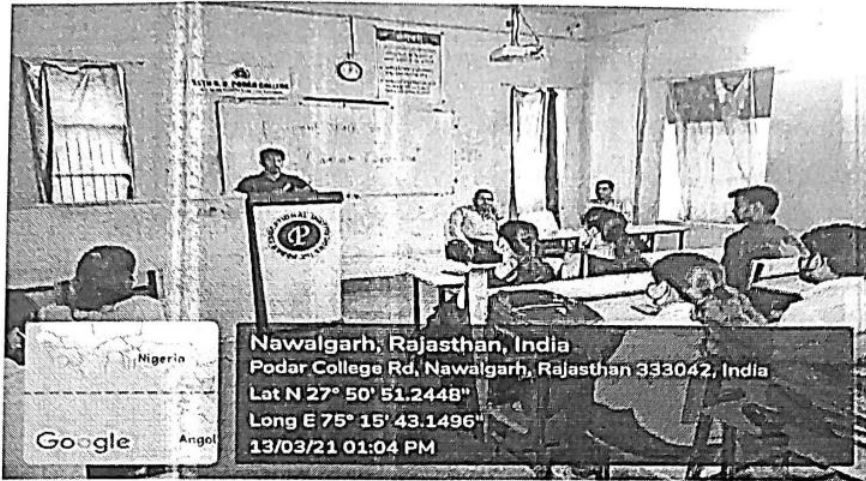

Dignitaries on the Dias & Speaker Addressing Students

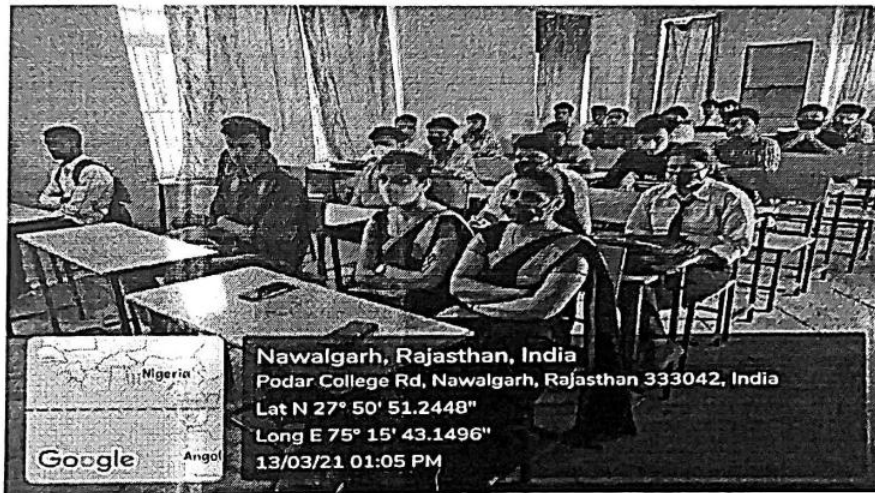

Department Staff and Students

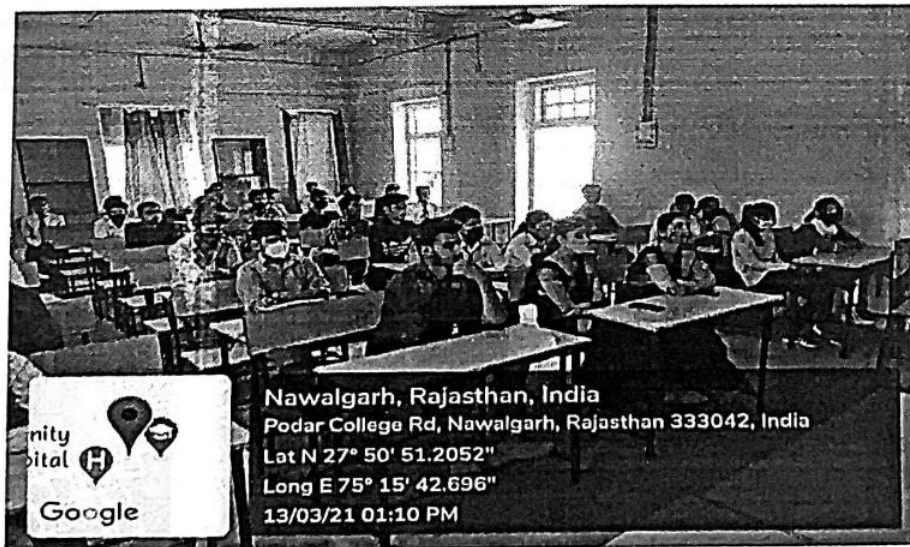

Lecture Session

Principal
Seth G.B. Podar College
Nawalgarh - 333042

पोदार में 'कॅरियर' विषय पर सेमिनार का आयोजन



न्यूज सर्विस/नवज्योति,
नवलगढ़। कस्बे के पोदार
कॉलेज के पोदार इंस्टीट्यूट
ऑफ मैनेजमेंट स्टडीज
विभाग में 'कॅरियर
काउणसलिंग' विषय पर
एक्सपर्ट लेकर पोदार

कॉलेज के पूर्व छात्र हितेश शर्मा, सॉफ्टवेयर इंजीनियर, टाटा कंस्लटेंट्सी
सर्विसेज अहमदाबाद द्वारा विद्यार्थियों को अपने कैरियर को विकसित
करने के लिए योजनाएं बनाने एवं कर्मचारियों की जरूरतों और संगठन
द्वारा प्रदान किए गए अवसरों के बीच अंतराल को उजागर किया। उन्होंने
बताया कि विद्यार्थी स्वयं अपनी क्षमताओं की पहचान और संगठनात्मक
अवसरों की खोज करें। इस व्याख्यान में बीबीए व बीसीए के विद्यार्थियों
ने भाग लिया। पोदार कॉलेज प्राचार्य डॉ. सत्येन्द्र सिंह व विभाग के
विभागाध्यक्ष प्रो. राकेश महला सहित अन्य व्याख्याता मौजूद रहें।

Principal
Seth G.B. Podar College
Nawalgarh - 333042

Counselling Common File

S. No.	Date	Form No.	Name Of Candidate	Father's Name	Address	Mobile No.	Last Class Attended	% In Last Class	Admission In	Name of Last Institution	Remark
1	29-07-2021	1001	Aman Gothwal	Shri Sandeep Gothwal	Dundlod	6377561828	12	73	Bcom. - I	Dundlod Vidyapeeth, Dundlod	Registered (Bcom - I)
2	29-07-2021	1002	Rishab Dev Mishra	Shri Kanhaya Lal Mishra	Nawalgarh	8905699400	12	72	Bcom. - I	Dundlod Vidyapeeth, Dundlod	Reg. (BBA - I)
3	30-07-2021	1003	Ritu Kumari	Shri Khyali Ram	Todpura	9783685458	MSC (P) Che.	PRO.	MSC (F) Che.	Podar College, Nawalgarh	Reg. MSC (F) Chemistry
4	6/9/2021	1004	Aarti Meena	Shri Rohitash Meena	Ward No. - 7, Lohagiradi, Nawalri	6377280033	12	84	BA - I	Choudhary Parneshwar Govt. School, Nawalri	Reg. BA - I (Geo)
5	2/8/2021	1005	Manish Soni	Shri Suresh Kumar Soni	Mandawa	8955676926	12	72.5	Bcom. - I	Dundlod Vidyapeeth, Dundlod	Registered (Bcom - I)
6	2/8/2021	1006	Amit Jha/hariya	Shri Yogesh Kumar	Near Bus Depo. Nawalgarh	8696808353	12	73	BBA	Sent Jon School, Sikar	Reg. (BCA-I)
7	5/8/2021	1007	Manoj Nagara	Shri Shankar Lal Nagara	Dhaka Ki Dhani, Nawalgarh	9636318954	12	55	BSC - I Bio	Govt. Sr. Sec. School, Harshana, Fatehpur	Reg. (BSC - III (B))
8	6/8/2021	1008	Avinash Mahala	Shri Virendra Singh	Ward No. - 10, Near Bal Vidya Mandir, Doomra	8114465671	12	65	BSC - I Bio	Podar GPS, Nawalgarh	Reg. (BSC - III (B))
9	6/8/2021	1009	Sakshi	Shri Chiranjil Lal	Chuna Chowk, Nawalgarh	9660385548	12	90	BSC - I Maths	Subhodh School, Nawalgarh	Reg. (BSC - I (M))
10	6/8/2021	1010	Sidisha	Shri Rajesh Kumar	Bhagat Singh Colony, Nawalgarh	6376449395	12	89.6	BSC - I Maths	Subhodh School, Nawalgarh	Reg. (BSC - I (M))
11	8/8/2021	1011	Sovab Chobdar	Shri Sakur Chobdar	Ward no. - 14, Dundlod	8426992796	12 Com.	74	Bcom - I	Shri Shyam Niketan	Reg. Bcom - I
12	10/8/2021	1012	Yogendra Singh	Shri Om Prakash Kalyan	Bagoriyon Ki Dhani, Nawalgarh	9983510426	12	84	BSC - I (Bio)	Navjivan School, Sikar	Reg. BSC - I (B)
13	13/08/2021	1013	Krish Kumar	Shri Rakesh Kumar	Kaseru, Nawalgarh	8209889639	12	82	BA - I	Saraswati School, Mukundgarh	Reg. BA - I (Geo)
14	14/08/2021	1014	Kamal Soni	Shri Shanwan Soni	Ward No. - 4, Main Chouraha, Kaseru	7742836967	12	76	BA - I	Saraswati School, Mukundgarh	Reg. BA - I (Geo)
15	17/08/2021	1015	Ankit Kaler	Shri Rajesh Kaler	Ward No. - 7, Sotwara, Nawalgarh	7014924772	12	98.4	BSC - I Maths	Subhodh School, Nawalgarh	Reg. Bsc - I (Maths)
16	19/08/2021	1016	Sakshi Agarwal	Shri Rajesh Kumar	Bagariyo Ki Haveli, Nawalgarh	6377918396	12	90	BSC - I (Bio)	SN School, Nawalgarh	Reg. (BSC - I (B))
17	21/08/2021	1017	Abhay Kumar	Shri Mahesh Kumar	Meelo Ki Dhani, Ward NO. - 2, Nawalgarh	9057029987	12	85	BA - I	Govt. School, Bay	Reg. BA - I (Gen)
18	23/08/2021	1018	Himani Jariya	Shri Yogesh Jariya	Ward No. - 9, Nansa Gate, Nawalgarh	9509008586	12	94.8	Bcom. - I	Podar School, Hindi Medium	Registered (Bcom - I)
19	24/08/2021	1019	Rahul Kumar Saini	Shri Parmeshwar Lal Singh	Dundlod	6375883575	12		Bsc - I (Maths)	DVP, Dundlod	Reg. BSC - I (M)
20	25/08/2021	1020	Nikita Kumari	Shri Rajendra	Ward No. - 9, Khinwasar	9983824274	12	87	BA - I	Sr. Sec. School, Khinwasar	Reg. BA - I (Gen)
21	27/08/2021	1021	Virendra Singh	Shri Mahendra Singh	Dinwa, Ladkhani, Fatehpur	9983024232	12	84	BA - I	Dedraj Madhyamik School	Reg. BA - I Geo
22	27/08/2021	1022	Rajnandini	Shri Ramanand	Ward No. - 9, Ramdevra, Mital Medical, Nawalgarh	9079744148	12	50	Bsc - I (Maths)	Sekhshariya School, Nawalgarh	Reg. BSC - I (M)
23	28/08/2021	1023	Tanisha Sharma	Shri Shankar Sharma	Near Govt. Hospital, Bawari Gate, Nawalgarh	8058328550	12	88	BBA - I	Bela Bai	Reg. BBA - I
24	28/08/2021	1024	Ishika Didwania	Shri Daya ram	Near Bari Masjid	9660237166	12	89	BBA - I	Gujrat	Reg. BBA - I
25	30/08/2021	1025	Krishan Kant	Shri Kanhaya Mishra	Bawari Gate, Nawalgarh	9929728437	12	86	BBA - I	Neharu Public School, Bawari Gate, Nawalgarh	Reg. BCA - I
26	30/08/2021	1026	Rohitash	Shri Rajendra Singh	Ward No. - 17, Mitharwal Ki Dhani, Khirod	9950093355	12	80	BA - I	Saraswati Bal Niketan, Khirod	Reg. BA - I Geo
27	31/08/2021	1027	Rahul Meena	Shri Rajesh Kumar Meena	Ward No. - 2, Ghoriwara Kalan	9928265700	12	75	Bsc - I (Bio)	Subodh School, Nawalgarh	Reg. Bsc - I (Bio)
28	31/08/2021	1028	Aman Salvad	Shari Amjad Saiyad	Ward No. - 21, Near Rani Sati, Nawalgarh	800556985	12	46	BBA	Bela Bai School, Nawalgarh	Reg. BBA - I
29	31/08/2021	1029	Mukesh Kumar	Shri Birbal Maharda	Ward no. - 6, Kudan, Sikar	6375508400	12	71	BA - I	Govt. School, Sihot	Reg. BA - I (Geo)

Principal
Seth G.B. Podar College
Nawalgarh - 333004

30	31/08/2021	1030	Preetam	Shri Chetram	Loyal, Khetri	8118854746	12	83	BSC - I (Maths)	Ummed School, Chanana	Reg. MSc (P) Physics
31	19/08/2021	1031	Aman Sharma	Shri Pawan Kumar Sharma	Ward No. - 2, Nagarpura, Nawalgarh	9772517675	12	81.9	BSC - I (Maths)	DVP, Dundlod	Reg. BSC - I (M)
32	1/9/2021	1032	Rinku Dhewa	Shri Bajrang Lal Dhewa	Chainram Ka Bass, Dharamshala, Beri	6378332902	12	96.6	Bsc - I (Maths)	Subodh School, Nawalgarh	Reg. BSC - I (M)
33	1/9/2021	1033	Dimpal Kanwar	Shri Prakash Singh	Ward No. - 15, Khirod	9950552236	12	75	BA - I	Bal Vidya Mandir, Khirod	Reg. BA - I (Geo)
34	1/9/2021	1034	Vikas Kumar	Shri Rajesh Kumar	Ward no. - 12, Nawalgarh	9929466077	12	78	Bsc - I (Maths)	DPS Dundlod	Reg. Bsc - I (Maths)
35	3/9/2021	1035	Karan	Shri Lokesh Saini	Ward no. - 5, Churi Ajitgarh	9116915145	12		Bsc - I (Maths)	Swami Keshwanand, Sikar	Reg. BSC - I (M)
36	3/9/2021	1036	Priyanka	Shri Babul Saini	Ward no. - 1, Lakha wala Johara, Nawalri	9785782453	12	84	BA - I	Govt. School	Reg. BA - I Geo
37	3/9/2021	1037	Vijay Yadav	Shri Bhagchand Yadav	Ward No. - 5, Patela Wali Dhanl, Shahpura	9610444056	12	79.4	Bsc - I (Maths)	Saraswati School, Balwantpura	Reg. Bsc - I (Bio)
38	4/9/2021	1038	Samiksha Patidia	Shri Kurda Ram Patidia	Ward no. - 11, Near Bus Stand, Bay	9414983438	12	84	BA - I	Govt. School	Reg. BA - I (Gen)
39	4/9/2021	1039	Kamlesh Saini	Shri Vinod Kumar	Ward No. - 18, Sainiprua	8000721610	12	76	BCA - I	Govt. School, Sainipura	no
40	6/9/2021	1040	Pooja	Shri Birju Singh	Ward No. - 8, Dhawra Ki Dhanl, Nawalgarh	9680599516	12	77.8	BA - I	Govt. School, Nawalri	Reg. BA - I Geo
41	27/08/2021	1041	Ankit	Shri Ramkumar Bhinchar	Churi Miyan, Ward No. - 2	8949626549	12	89	Bsc - I (Maths)	Subodh School, Nawalgarh	Reg. BSC - I (M)
42	8/9/2021	1042	Rohit	Shri Vijay Singh	Ward No. - 7, Sotwara	9887376590	12	85	Bsc - I (Maths)	Subodh School, Nawalgarh	Reg. BSC - I (M)
43	8/9/2021	1043	Uttam Ghorela	Shri Surendra Ghorela	Ghoomchakar, Station Road	9001906361	12	56	Bcom - I	GPS	Reg. Bcom - I
44	8/9/2021	1044	Chanchal Jangir	Shri Vinod Kumar Jangir	Pujari Ki Dhanl, Nawalgarh	8432291113	12	92.6	Bcom - I	GIN Gudha Gorji	no
45	9/9/2021	1045	Pankaj Kumar Lamba	Shri Dharmal Singh	Ward No. - 9, Chelasi	9119154838	12	75	Bsc - I (Maths)	DPS	Reg. BSC - I (M)
46	10/9/2021	1046	Mohit Chalka	Shri Jaiprakash	Ward No. - 10, Khinwasar	9352699245	12	75	Bsc - I (Maths)	New Indian School, Nawalgarh	Reg. BCA - I
47	10/9/2021	1047	Ankit Kumar	Shri Sultan Singh	Nochwa Ki Dhanl	7665130675	12	85	BA - I	Saraswati Bal Niketan	Reg. BA - I Geo
48	10/9/2021	1048	Nisha Kharinta	Shri Dhura Ram	Sonthali, Titanwar	9509000037	BSC - III	68.22	Msc (P) Zoology	Bal Sadhana Girls College, Gudha Gorji	Reg. MSc (P) Zoology
49	11/9/2021	1049	Nilam Verma	Shri Mahendra Kumar	Jakhot, Surajgarh	8619181937	BSC - III		MSc (P) Physics	Rama Devi PG College	Reg. MSc (P) Physics
50	12/9/2021	1050	Vijesh Saini	Shri Balram Saini	Ward No. - 11, Udaipurwati	8875392428	12	56	BA - I	Saraswati Sr. Sec. School, Udaipurwati	Reg. BA - I Geo
51	13/09/2021	1051	Rajiv Jangir	Shri Dinesh Jangir	Ward No. - 7, Rashulpur, Khetri	7877700387	12	87	Bsc - I (Maths)	Sanskar Public School, Barau	Reg. BSC - I (M)
52	14/09/2021	1052	Preetam	Shri Rajveer	Ward No. - 9, Bhojasar	7976561912	12	75	Bsc - I (Bio)	DVP, Dundlod	no
53	14/09/2021	1053	Komal	Shri Rajendra Kumar	Ward No. - 8, Naya Parasrampura	8171990368	12	92	BSC - I (Bio)	Sanskar Acadmy	Reg. BSC - I (Bio)
54	15/09/2021	1053	Komal Mandiya	Shri Rajendra Kumar Mandiya	Ward No. - 8, Naya Parasrampura	8171990368	12	92	Bsc - I (Bio)	Sanskar Public School, Gudha Gorji	Reg. Bsc - I (Bio)
55	15/09/2021	1054	Ronak Kumar	Shri Mahaveer Prasad	Ward No. - 3, Devgaon, Parasrampura	9982224757	12	82.6	Bsc - I (Maths)	Modia Tiba, Naya Parasrampura	Reg. Bsc - I (Maths)
56	15/09/2021	1055	Anshul	Shri Nemichand Bhinchar	Ward No. - 7, Churi Miyan	8104758594	12	92.4	Bsc - I (Bio)	Subodh School, Nawalgarh	Reg. Bsc - I (Bio)
57	16/9/2021	1056	Anurag Royal	Shri Sharwan Kumar	Bidasar, Sikar	9983700631	12	93.6	BA - I	DPS Dundlod	Reg. BA - I Geo
58	10/9/2021	1057	Sushma	Shri Sohan Lal	Bidasar, Sikar	9983700631	12	88.6	BA - I	DPS Dundlod	Reg. BA - I Geo
59	17/09/2021	1058	Kamal Yadav	Shri Mahendra Yadav	Ward No. - 4, Balaji Ka Nada, Beri, Sikar	9950465817	12	77	Bsc - I (Maths)	Prerna School	Reg. Bsc - I (Maths)
60	18/09/2021	1059	Sonu Kumar	Shri Surendra Kumar	Ward No. - 4, Bhojnagar	7231038898	12	80	Bsc - I (Maths)	Subodh School, Nawalgarh	Reg. Bsc - I (Maths)

Principal
Seth G.B. Pooja
Nawalgarh

61	18/09/2021	1060	Kamlesh	Shri Deshraj	Ward No. - 6, Ghoriwara Khurd	6375382366	13	77	Bsc - I (Maths)	Subodh School, Nawalgarh	Reg. Bsc - I (Maths)
62	20/09/2021	1061	Aman	Mohd. Faruq	Mohalla Barudgran, Nawalgarh	9079132558	12	70	Bcom - I	Mansingh Ka School, Nawalgarh	Reg. Bcom - I
63	22/09/2021	1062	Javed Kureshi	Shri Sagir Kureshi	Ward No. - 6, Churi Ajitgarh, Mukundgarh	789104069	12	65	Bcom - I	DVP Dundlod	Reg. Bcom - I
64	22/09/2021	1063	Chitanshu Yadav	Shri Ved Prakash Yadav	Ward No. - 20, Dundlod	6350201534	12	65	Bcom - I	DVP Dundlod	Reg. Bcom - I
65	23/09/2021	1064	Mukhram Saini	Shri Ramawatar Saini	Ward No. - 6, Gangasagar Ki Dhani, Chelasi	7688929339	12	52	Bsc - I (Bio)	Mansingh Ka School, Nawalgarh	Reg. Bsc - I (Bio)
66	23/09/2021	1065	Mukesh Kumar	Shri Ramawatar Poonia	Ward No. - 2, Pujari Ki Dhani, Nawalgarh	8769421045	12	84	Bsc - I (Bio)	Mansingh Ka School, Nawalgarh	Reg. Bsc - I (Bio)
67	23/09/2021	1066	Rahul	Shri Vijendra Kumar	Mandi Gate, Nawalgarh	7424823162	12	86	Bsc - I (Maths)	Mansingh Ka School, Nawalgarh	No
68	23/09/2021	1067	Ankit	Shri Randheer Singh	Ward No. - 9, Barwasi, Nawalgarh	9829693305	12	65	Bsc - I (Maths)	SBS School	Reg. Bsc - I (Bio)
69	27/09/2021	1068	Priyanka Kumawat	Shri Prahlad Kumawat	Near Shyam Mandir, Ward No. - 21, Dundlod	9024410049	12	68	BA - I	Govt Girls School, Dundlod	Reg. BA - I Geo
70	27/09/2021	1069	Aditya Jangir	Shri Ramswaroop Jangir	Nadipura, Sikar	9024549494	12	78	Bcom - I	Mandawa	Reg. Bcom - I
71	27/09/2021	1070	Ankit Kumar Kumawat	Shri Subhash Chand	Rana Wali Dhani, Raghunathgarh	9610558034	12	80.09	Bsc - I (Bio)	Sahid Ramniwas Sanu Govt. School	
72	27/09/2021	1071	Rinku Kumar	Shri Kishor Kumar Saini	Ward No. - 1, Nawalri	7014002928	12	83.8	Bsc - I (Bio)	Saraswati School	Reg. Bsc - I (Bio)
73	28/09/2021	1072	Vishal Kaler	Shri Tarachand Kaler	Ward No. - 19, Dundlod	9588867799	12	80	Bsc - I (Maths)	New Rajasthan, Fatehpur	
74	28/09/2021	1073	Kritika Mishra	Shri Anil Kumar Mishra	Ward No. - 43, Nawalgarh	7412829551	12	86	Bsc - I (Bio)	Sekhshariya School, Nawalgarh	Reg. Bsc - I (Bio)
75	28/09/2021	1074	Laxmi Jagrat	Shri Ganesh Jagrat	Ward No. - 22, Nawalgarh	9521722651	12	91	Bsc - I (Maths)	Gayatri School	Reg. Bsc - I (Maths)
76	29/09/2021	1075	Naima Khatri	Mohd. Sabira nasir	Ward No. - 3, Gandhipark, Nawalgarh	8949886128	12	77.6	BA - I	Goutambal Niketan,	Reg. BA - I Geo
77	9/29/2021	1076	Ankit Kumar	Shri Rajendra Singh	Jhahhariya Ki Dhani	8302154308	12	86	Bsc - I (Bio)	Govt. School	Reg. Bsc - I (Bio)
78	9/29/2021	1077	Mohd. Abdul Rahman	Mohd. Arif Husaln	Bakara Mandi, Bari Masjid, Nawalgarh	7568343488	12	66	Bcom - I	SN School, Nawalgarh	Reg. Bcom - I
79	29/09/2021	1078	Vikash Mahala	Shri Prahlad Ray	Jogiyo Ka Bass, Nawalgarh	9116863986	12	64	BA - I	Goutambal Niketan,	Reg. BA - II Geo
80	29/09/2021	1079	Anshu	Shri Banwari Lal	Keshar Nagar, Kolida	9983182692	12	68	BA - I	Todi College	
81	29/09/2021	1080	Vijapal	Shri Mahesh Yogi	Kolida	8875489225	12	63	BA - I	Govt School	
82	29/09/2021	1081	Vikas Khichar	Shri Rajendra	Beri, Dharmshala	9610227098	12	78	BA - I	Bharatiya Public School, Sikar	
83	9/30/2021	1082	Swati	Shri Omprakash Jangir	Poonia Ka Bass, Bidasar	8279252466	12	88	BA - I	Gramin School	Reg. BA - I Geo
84	9/30/2021	1083	Payal Saini	Shri Narendra Saini	Anthia Wali Dhani, Nawalgarh	9785177917	12	90	BA - I	Subodh School	Reg. BA - I Geo
85	9/30/2021	1084	Aditya Jangir	Shri Omprakash Jangir	Ward No. - 3, Nawalri, Nawalgarh	7073833867	12	78	BA - I	Govt School	Reg. BA - I Geo
86	9/30/2021	1085	Amit	Shri Rajendra Kumar	Kolida, Keshar Nagar	852904221	12	66	BA - I	Govt School	Reg. BA - I Geo
87	9/30/2021	1087	Nayum Khan	Mohd. Fayad	Churiwalo Ki Havelli, Ward No. - 27, Nawalgarh	9828387363	12	73	Bcom - I	Vishwa Bhartiya School	Reg. Bcom - I
88	9/30/2021	1088	Nikita Kumari	Shri Bhanwar Lal	Birodi Chhoti, Sikar	8107991635	12	81	BA - I	New Indian School	Reg. BA - I Geo
89	9/30/2021	1089	Mohd Sameer	Mohd. Sallm	Ward No. - 6, Jokhiram Ka Kua	7742464172	12	43	BA - I	New Indian School	
90	10/1/2021	1090	Ranjana	Shri Birbal Kumawat	Ward No. - 3, Bidasar	9660233585	12	83.6	BA - I	Govt. Bidasar	
91	10/1/2021	1091	Rohit Chouhan	Shri Birjoram Chouhan	Ward No. - 1, Ramgarh Shekhawati	9001419600	12	85	Bsc - I (Maths)	Shekhawati Shikshan Sansthan	
92	6/8/2021		Soyab Chobdar	Shri Rakur Chobdar	Ward No. - 2, Dundlod	8426992796	12	74	Bcom - I	Shyam Vidya Niketan, Dundlod	NO

Principal
Seth G.B. Pooja College
Nawalgarh

93	14/09/2021	Ankit Kumar	Shri Girdhari Lal	Tonk Chhilari, Nawalgarh	8302939679	12	79	Bcom. - I	Govt. School, Bhojnagar	NO
94	14/09/2021	Pratap Singh Verma	Shri Ghasi Ram	Tonk Chhilari, Nawalgarh	9587108830	12	84	Bcom. - I	Govt. School, Bhojnagar	NO
95	27/09/2021	Abdul Rahman	Shri Arif Khatri	Ward No. - 30, Bakara Mandi	7568343483	12	77	Bcom. - I	SN School	NO
96	27/09/2021	Aavesh	Shri Rahim Ahmad	Ward No. - 1, Nawalgarh	8619779974	12	80	BCA	SN School	NO
97	27/09/2021	Mohd. Sameer	Mohd. Saleem	Ward No. - 2, Nawalgarh	7877267098	12	86	BCA	SN School	NO
98	2/8/2021	Jagarti Chotiya	Shri Sunil Kumar Chotiya	Ward No. - 13, Mandi Gate, Nawalgarh	9079688916	12	89	BSC - I Maths	Saraswati School, Dundlod Fatak	no
99	3/8/2021	Praveen Kumar	Shri Ramniwas Khanwas	Ward NO. - 03, Dhanya Bhorki	8905260866	12	89	BSC - I Maths	Gita Bal Niketan, Bhorki	Reg. (BSC - III (M))
100	6/8/2021	Shankar Saini	Shri Suresh Saini	Bawari Gate, Nawalgarh	7976277499	12	72	BCA	Podar School, Hindi Medium	no
101	6/8/2021	Rohitash	Shri Moolchand Meel	Near Govt. School, Kolida	9358929695	12	78	BSC - I Bio	Govt. Sr. Sec. School, Kolida	no
102	6/8/2021	Hemant Singh	Shri Pape Singh	Near Govt. School, Kolida	9784141792	12	80	BSC - I Bio	Govt. Sr. Sec. School, Kolida	no
103	6/8/2021	Manish	Shri Mahesh Kumar	Near Govt. School, Kolida, Tarpura Stand	7891765261	12	91	BSC - I Bio	Govt. Sr. Sec. School, Kolida	Reg. (BSC - I (M))
104	6/8/2021	Umesh	Shri Laxman Ram	Veena Das Ki Dhani, Kari	8209082852	12	84	BSC - I Bio	Nehru Public School, Bhagera	no
105	7/8/2021	Sachin	Shri Ruknand Khatri	Ward no. - 10, Glnages Colony	8284971019	12 Maths	75	BSC - I	S.N. School	no
106	7/8/2021	Karan Khatri	Shri Bishambhar	Ward no. - 10, Glnages Colony	8284971019	12 Com	83	BSC - I	S.N. School	no
107	10/8/2021	Satveer Singh	Shri Laxman Singh	Azad Nagar, Deenwa, Sikar	9799517194	12	78	BSC - I Maths	Adrash Vidya Mandir, Mandawa	no
108	10/8/2021	Balveer Singh	Shri Ladu Singh	Azad Nagar, Deenwa, Sikar	9983629428	12	80	BCOM - I	Adrash Vidya Mandir, Mandawa	no
109	11/8/2021	Aditya Meel	Shri Sant Kumar Meel	Sundo Ki Dhani, Barwasi	9929629463	12	80	BSC - I Maths	IPS School, Niwai	Reg. (BSC - I (M))
110	11/8/2021	Jagveer Dhaka	Shri Nagarmal	Dhaka Ki Dhani, Nawalgarh	8432702462	12	90	BCA	Navjivan Science, School, Sikar	no
111	16/08/2021	Devraj Singh	Shri Babu Singh	Deenwa, Sikar	7073697077	12	89	BSC - I Maths	Mandawa	no
112	16/08/2021	Akul Singh	Shri Ranmal Singh	Deenwa, Sikar	7073697077	12	85	BSC - I Maths	Mandawa	no
113	16/08/2021	Ronak Kumar	Shri Mahaveer	Devgaon, Parasrampura	9982224757	12	82	BSC - I Maths	Modia Tiba, Naya Parasrampura	no
114	16/08/2021	Harsh Podar	Shri Sushil Podar	Bus Stand, Parasrampura	8058004092	12	81	BCA - I	Gudha Public School	no
115	16/08/2021	Saniya	Shri Suresh	Ward no. - 7, Doomra, Nawalgarh	9664015060	12	91	BSC - I Bio	Shri Bal Vidya Mandir, Doomra	no
116	16/08/2021	Ankit Kumar	Shri Mahendra Kumar	Ward No. - 10, Mukundgarh	8005753164	12	73		Prince Sikar	no
117	17/08/2021	Ankita Kaler	Shri Rajesh Kaler	Ward No. - 7, Sotwara, Nawalgarh	7877962738	12	93.4	BSC - I Maths	Subhodh School, Nawalgarh	no
118	18/08/2021	Pritam Kumar	Shri Mahesh Kumar	Delsar kalan, Nawalgarh	7357224084	12	90	BSC - I Bio	Tagore Sr. Sec. School	no
119	18/08/2021	Mohd. Sameer	Mohd. Salim	Bay, Nawalgarh	9672729703	12	82	BCA	Sr. School, Bay	no
120	19/08/2021	Ankit Kumar	Shri Mahesh Kumar	Barwasi, Nawalgarh	9521179127	12	88	BSC - I (Maths)	Prince Sikar	no
121	19/08/2021	Neeraj Verma	Shri Namichand Verma	Churi Ajjgarh	9649863213	12	76	BCA	DVP, Dundlod	no
122	21/08/2021	Pooja Kumari	Shri Mahesh Kumar	Ward No. - 1, Kalru	9667934428	12	94	BSC - I (Bio)	Bal Vidya Mandir, Doomra	no
123	21/08/2021	Anu Dudi	Shri Surendra Singh	Ward No. - 10, Kolsiya	7742972872	12	84	BSC - I (Maths)	Shekhawati School, Dundlod	Reg. (BSC - I (M))
124	23/08/2021	Lalita	Shri Bhanwar Lal	Ward NO. - 10, Dudwa	9549707677	12	90	BSC - I (Maths)	MK Memorial, Laxmangarh	no
125	23/08/2021	Ajay Singh	Shri Vijay Singh	Ward NO. - 07, Sotwara	9414743280	12	84	BSC - I (Maths)	Subhodh School, Nawalgarh	no
126	23/08/2021	Himanil	Shri Sunil Kumar	Ward No. - 11, Nawalgarh	9785129617	12	88	BSC - I (Bio)	Prerna School, Nawalgarh	Reg. (BSC - I (B))

Principal
Seth G.B. Podar College
Nawalgarh

157	16/09/2021	Neeraj	Shri Nemichand Varm	Ward No. - 9, Ajitgarh	9649863213	12	76	BCA - I	DVP, Dundlod	no
158	16/09/2021	Dinesh Kumar	Shri Ashok Kumar	Near Tarpura Stand, Beri	8302703959	12	87	BSC - I (Maths)	DPS, Dundlod	No
159	21/09/2021	Devendra	Shri Rukmanand	Near Ramdev Ji Mandir	7240635165	12	73	BSC - I (Maths)	SN School, Nawalgarh	No
160	21/09/2021	Akshay Kumar	Shri Subhash Chandra	Ward No. - 6, Jejusar, Nawalgarh	9610558034	12	80	BSC - I (Bio)	Govt. School, Jejusar	No
161	21/09/2021	Mukesh Kumawat	Shri Gori Shankar Kumawat	Ward No. - 29, Jamat, Udalpurwati	6367650933	12	89	BCA		NO
162	21/09/2021	Param Saini	Shri Ramchandra Saini	Ward No. - 30, Udalpurwati	8690731164	12	88	BCA		NO
163	22/09/2021	Ankit Kumar Gurjar	Shri Omprakash Gurjar	Ward No. - 16, Khirod, Nawalgarh	9799040358	12	95	BSC - I (Maths)	Saraswati School, Khirod	No
164	22/09/2021	Rahul Saini	Shri Sajjan Saini	Ward No. - 3, Jhajhar	9549971783	12	82	BSC - I (Maths)	Subhodh School, Nawalgarh	No
165	24/09/2021	Ankit Yadav	Shri Sanwermal Yadav	Dhamani Johari, Basawa	7023919151	12	91.6	BSC - I (Maths)	New Indian School	no
166	24/09/2021	Priyanshu Sharma	Shri Gajanand Sharma	Birodi Chhoti	8209873294	12	83	BSC - I (Maths)	Prerna School, Nawalgarh	No
167	28/09/2021	Dashrath Singh	Shri Kailash Singh	Ward No. - 5, Kaseru	7877698658	12	87	BSC - I (Maths)	Govt. School, Ghoriwara Kalan	no
168	29/09/2021	Rahul Kumawat	Shri Remniwas Kumawat	Pipli Chowk, Nawalgarh	9828193689	12	83.6	BSC - I (Maths)	Subhodh School, Nawalgarh	NO
169	29/09/2021	Vijendra Kumawat	Shri Ratan Lal Kumawat	Pipli Chowk, Nawalgarh	9828193689	12	83.6	BSC - I (Maths)	Subhodh School, Nawalgarh	NO
170	29/09/2021	Arvind Kumar Kumawat	Shri Sultan Kumawat	Pipli Chowk, Nawalgarh	9664421343	12	83.6	BSC - I (Maths)	Subhodh School, Nawalgarh	No
171	29/09/2021	Ashish Kumar	Shri Bhagwati Prasad	Kolsiya	8955991195	12	91.4	BSC - I (Maths)	Govt. School, Kolsiya	
172	29/09/2021	Manish	Shri Mahendra	Kemari Ki Dhani, Khirod	9024701940	12	90	BSC - I (Maths)	Sunsine Public School	
173	9/30/2021	Sohel	Shri Faruq Ali	Puran Masjid ke Pass, Ghoriwara Khurd	8619410447	12	79	BSC - I (Maths)	Govt. School, Ghoriwara Kalan	
174	9/30/2021	Rahul	Shri Bhinwa Ram	Birodi Chhoti	8290877460	12	82	BSC - I (Maths)	Prerna School, Nawalgarh	
175	10/1/2021	Tanuja Sharma	Shri Pyare Lal Saini	Mohabatsar, Ward No. - 11	9772520473	12	80	BSC - I (Bio)	Podar Hindi Medium	
176	10/1/2021	Monika Saini	Shri Tarachand Saini	Ward No. - 2, Sarda Wali Dhani	9783044366	12	84	BSC - I (Bio)	Podar Hindi Medium	
177	10/1/2021	Umesh	Shri Omprakash	Basawa, Nawalgarh	9928625382	12	80	BSC - I (Maths)	Subhodh School, Nawalgarh	
178	2/8/2021	Sameer	Shri Saleem	Bakara Mandi, Nawalgarh	9680491020	12	79	BA - I GEN	Galobal Acadmy	no
179	2/8/2021	Nirma	Shri Harphool Khedar	Beri, Swarooppura	9784371576	12	85	BA - I Geo	Saraswati School, Beri	no
180	2/8/2021	Ranjan	Shri Prahlad Ray	Jatwali, Mukundgarh	9929550218	12	72	BA - I	Churi Ajitgarh, Badriprasad	no
181	2/8/2021	Ghanshyam	Shri Ramdhan	Ward No. - 2, Churi Ajitgarh	9602906857	12	75	BA - I	Churi Ajitgarh, Badriprasad	no
182	2/8/2021	Mubarik	Shri Jafar Ali	Ward NO. - 18, Mukundgarh	7297095590	12	88	BA - I	Churi Ajitgarh, Badriprasad	no
183	2/8/2021	Surendra Kumar	Shri Bajran Lal	Ward No. - 2, Churi Ajitgarh	7300313804	12	71	BA - I	Churi Ajitgarh, Badriprasad	no
184	2/8/2021	Dinesh	Shri Suresh Kumar	Ward No. - 2, Churi Ajitgarh	7891101985	12	78	BA - I	Churi Ajitgarh, Badriprasad	no
185	3/8/2021	Anil Kumar	Shri Rammohan Kharbas	Ward No. - 3, Bhorki	6376770702	12	81	BA - I	Sanskar Science Acadmy, Gudha Gorji	no
186	4/8/2021	Jabid Ali	Shri Umardeen Kureshi	Ward No. - 2, Barwasi	7296919750	MCOM	78	MA (Pol. Sci.)	Raj University	no
187	4/8/2021	Shivani Kumawat	Shri Keshar Mal Kumawat	Near Bugalia School, Parasrampura	9672108874	12	87	BA - I	Bugalia School, Parasrampura	no

Printed
Seth G. B. Podar College
Nawalgarh - 333041

188	6/8/2021	Ajay	Shri Narendra Kumar Saini	Saini Nagar, Chobdaro Ki Dhani, Nawalgarh	8000432599	- 12	74.04	BA - I	Subodh School, Nawalgarh	no
189	13/08/2021	Nitin Saini	Shri Gulab Chand Saini	Lala Wali Dhani, Nawalgarh	7851021101	12		BA - I	Sager Sr. Sec. School, Nawalgarh	no
190	16/08/2021	Deepak Jakhar	Shri Shyam Lal	Ward No. - 3, Birodi Bari, Laxmangarh	7728989563	12	81	BA - I		Reg. BA - I (Geo)
191	16/08/2021	Virendra Singh	Shri Mahendra Singh	Deenwa, Sikar	9983024232	12	82	BA - I	Mandawa	no
192	18/08/2021	Abhishek Kumawat	Shri Rohitash Kumawat	Harijan Mohalla, Niwai	7340079743	12	86	BA - I	Inaliya School, Niwai	Reg. BA - I (Geo)
193	18/08/2021	Monika Garwa	Shri Vijay Kumar Garwa	Siriyasar Kalan, Dighal	7821064930	12	87	BA - I	Govt. School, Siriyasar Kalan	no
194	27/08/2021	Ravindra	Shri Ramchandra	Poonia Ka Bass, Bidsar	9549190121	12	85	BA - I	Saraswati School, Nawalgarh	no
195	3/9/2021	Nitin	Shri Gulab Saini	Ward No. - 15, Nawalgarh	9461484526	12	83	BA - I	Sagar Vidya Mandir	no
196	6/9/2021	Surendra Saini	Shri Rameshwar Lal Saini	Mishra Wali Dhani, Nawalgarh	7891517380	12	80	BA - I	Sagar Vidya Mandir	no
197	17/09/2021	Sangeeta	Shri Gangadhar Singh	Ward No. - 13, Khojawas, Basawa	8426037594	12	76	BA - I	Govt. School, Bhojnagar	No
198	17/09/2021	Neha	Shri Gangadhar Singh	Ward No. - 13, Khojawas, Basawa	8426037594	12	78	BA - I	Govt. School, Bhojnagar	No
199	18/09/2021	Vishal Saini	Shri Pawan Kumar Saini	Ward No. - 4, Bhatiwali Dhani, Nawalgarh	6378005256	12	70.8	BA - I	Prerna School, Nawalgarh	No
200	18/09/2021	Payal	Shri Narendra Saini	Anthawali Dhani, Nawalgarh	9785177917	12	90	BA - I	Subodh School, Nawalgarh	No
201	20/09/2021	Harish Kuamwat	Shri Sanwar Mal	Kolsiya, Nawalgarh	7568213600	BSc (Maths)		MA (Pol. Sci.)	Podar College	No
202	20/09/2021	Amit Kumawat	Shri Moolchand	Kolsiya, Nawalgarh	9351852602	BSc (Maths)		MA (Pol. Sci.)	Podar College	No
203	20/09/2021	Prakash Saini	Shri Mangilal Saini	Ward No. - 9, Nawalri	8107333534	12	80	BA - I	Podar School	No
204	20/09/2021	Rinku Saini	Shri Ram Saini		7689975304	12	80	BA - I	Banarasi Devi School	No
205	22/09/2021	Sachin Jagrat	Shri Rajesh Kumar	Ambedkar Park, Ward No. - 32	8386088889	12	76	BA - I	Bharti Public School, Nawalgarh	No
206	23/09/2021	Dipesh Yadav	Shri Madhav Prasad Yadav	Ward No. - 25, Naya Bazar, Bhakto Ki Haveli	9929360992	12	70	BA - I	Bharti Public School, Nawalgarh	No
207	23/09/2021	Lokesh	Shri Phoolchand	Ward No. - 6, Nawalri	9785995026	12	79.2	BA - I	Govt. School, Nawalri	No
208	23/09/2021	Faruq	Shri Babulal	Naya Parasrampura	9785768671	12	77	BA - I	Bharat Mata Sr. Sec. School, Nawalgarh	No
209	25/09/2021	Swati	Shri Omprakash	Poonia Ka Bass, Bidsar	8279252466	12	88	BA - I	Gramin School, Sikar	No
210	25/09/2021	Narendra	Shri Ramkaran	Ward No. - 9, Bidasar	7305338986	12	86	BA - I	Marudhara	No
211	25/09/2021	Vikas Kumar	Shri Sajjan Singh	Ward No. - 9, Bidasar	8955739792	12	88	BA - I	Marudhara	No
212	25/09/2021	Sumeet Ranwa	Shri Dharmpal	Ward No. - 20, Khirod	8742857795	12	82.66	BA - I	Saraswati School, Balwantpura	No
213	25/09/2021	Nalma	Shri Nasir Khatri	Ward No. - 3, Nawalgarh	8003154020	12	77.6	BA - I	Goutam School	No
214	28/09/2021	Mohit	Shri Vinod Kumar	Niwai, Ward No. - 2	9785198301	12	85	BA - I	Imam School	No
215	28/09/2021	Vikas Khilchar	Shri Rajendra Khilchar	Ward No. - 8, Beri Dhamshala	9610227098	12	78	BA - I	Bhartiya School, Sikar	No
216	28/09/2021	Anshu		Ward No. - 7, Kolida	9983182692	12	70	BA - I	Govt. School	No
217	28/09/2021	Uttam Poonia	Shri Rajesh Kumar	Ward No. - 2, Poonia Ki Dhani, Nawalgarh	9461244275	12	80	BA - I	Prince School, Nawalgarh	No
218	30/09/21	Upendra	Shri Ramkumar	Khirod	6375618548	12	68	BA - I	Saraswati School, Balwantpura	No
219	30/09/21	Mukesh Kumar Sarwa	Shri Hira Lal	Bhojnagar, Parasrampura	7568892468	12	67	BA - I	Govt. School, Bhojnagar	No
220	9/30/2021	Aditya Jangir	Shri Omprakash	Ward No. - 3, Nawalri	7073833867	12	78	BA - I	Govt. School, Jhajhar	No
221	10/1/2021	Manjeet Rar	Shri Harisingh Rar	Ward No. - 3, Birol	8003650246	12	82	BA - I	Shekhawati School, Jhajhar	NO
222	10/1/2021	Pooja Saini	Shri Mohanlal	Nawalgarh	7742977540	12	82	BA - I	Govt. School, N	
223	31-07-2021	Amit	Shri Yogesh Kumar	Near Bus Depot, Nawalgarh	8696808353	12 Com.		BBA	Sent Jons School, Nawalgarh	Reg. BCA - I

Principal
G.B. Podar College
Nawalgarh

224	1/8/2021	Idrish Khan	Shri Ranjeet Khan	Ward No. - 11, Dundlod	7300220538	12 Com.	82	Bcom - I	Reads Public School, Dundlod	no
225	1/8/2021	Albin Thomas	Shri Thomas KK	Near Goyanka School, Dundlod	7014426601	12 Com.	73	Bcom - I	Reads Public School, Dundlod	no
226	11/8/2021	Yash Jangir	Shri Rajesh Jangir	Bhojasar, Nua	7427018161	12 Com.	78	Bcom - I	Saraswati School	Reg. Bcom - I
227	11/8/2021	Naveen Jangir	Shri Subash Jangir	Bhojasar, Nua	9784012236	12 Com.	80	Bcom - I	Saraswati School	Reg. BSC - I (M)
228	12/8/2021	Krishna Patwari	Shri Naresh Patwari		6377833667	12	77	BBA	Didwana	no
229	14/08/2021	Hemant	Shri Pawan Kumar	Pilani	9610333082	12	87	Bcom - I	CBSE Pilani	no
230	16/08/2021		Shri Rakesh	Narnol, Hariyana	7206260734	12	66	BBA		no
231	16/08/2021	Deepak Sharma	Shri Dilip Kumar	Ward No. - 24, Podar Gate, Nawalgarh	8529866114	12	79	Bcom - I	Bela Bai	no
232	16/08/2021	Aman Sayad	Shri Amjās Sayad	Ward No. - 34, Rani Sati Mandir Ke Pass	8005569025	12	46	BBA	Bela Bai	no
233	23/08/2021	Pankaj Mahala	Shri Shishram Mahala	Ward No. - 2, Kishas Ki Dhani, Doomra	9667127930	12	68	Bcom - I	Dundlod Vidhapeet School, Dundlod	Reg. Bcom - I
234	28/08/2021	Rakesh	Shri Sita Ram	Nawalgarh	9587061584	12	50	BCA - I	Gujrat	no
235	3/9/2021	Prakash Singh	Shri Ramswaroop Singh	Ward No. - 6, Churi Ajitgarh, Mukundgarh	6375993500	12	81	BBA - I	dundlod	no
236										no
237	7/9/2021	Chetan	Shri Vinod Koushik	Ward no. - 14, Dundlod	9529876588	12	72	BBA - I	DVP Dundlod	no
238	13/09/2021	Divya Sharma	Shri Kamal Kumar Sharma	Ward No. - 42,	9828265026	12	91	Bcom - I	Bela Bai	no
239	2/8/2021	Renu Kumari	Shri Rajendra Singh	Kuharwas, Jhunjhunu	9413635180	BSC - III	64.66	MSC (P) Physics	Bhaliya Devi PG College, Buhana	no
240	9/8/2021	Kalpna Singh	Shri Ram Singh	Ward No. - 10, Doomra	9560855874	12	89	BSC - I (Bio)	Saraswati School, Dundlod	no
241	24/08/2021	Reena Godara	Shri Ramniwas Godara	Near Subodh School, Choudhary Complex, Nawalgarh	6359697127	12	82	BSC - I (Bio)	Kendriya Vidyalaya, Ahamdabad Kent	no
242	27/08/2021	Anshul	Shri Nemichand	Churi Miyan, Ward No. - 2	8104758594	12	92	Bsc - I (Bio)	Subodh School, Nawalgarh	no
243	27/08/2021	Vikas	Shri Rajesh Kumar	Ward No. - 12, Nawalri	9929466077	12	78	Bsc - I (Maths)	DPS	no
244	28/08/2021	Dharmendra	Shri Karniram	Bungara, Tarpura	7231841031	12		Bsc - I (Maths)	Nalanda Public School, Sikar	no
245	13/09/2021	Prisha Soni	Shri Manoj Saini	Ward No. - 13, Bawari Gate, Nawalgarh	9352406396	12	62	Bsc - I (Bio)	DVP, Dundlod	no
246	2/8/2021	Maya Swami	Shri Dayaram Swami	Choudhani, Parasrampura	9680418038	12	72	BA - I	Govt. Sr. Sec. School, Parasrampura	no
247	4/8/2021	Saurabh Saini	Shri Rajendra Saini	Near Podar College, Nawalgarh	7665543621	12 (Maths)	84	BA - I	Prerna School, Nawalgarh	Reg. BA - I (Gen)
248	7/8/2021	Rajesh	Shri Harchand	Ward No. - 1, Bhanpura, Pujari Ki Dhani	9636328844	12 Arts	79.8	BA - I	Govt. School, Bay	no
249	7/8/2021	Vikki	Shri Neki Ram	Ward No. - 1, Bhanpura, Pujari Ki Dhani	7727859581	12 Arts	87	BA - I	Govt. School, Bay	no
250	7/8/2021	Kuldeep	Shri Shishram	Ward No. - 9, Pujari Ki Dhani	8875395702	12 Arts	75	BA - I	Govt. School, Bay	no
251	7/8/2021	Arti Kumawat	Shri Chouthmal	Ward No. - 11, Asalsar, Parasrampura	9799663545	12 Arts	82	BA - I	Bugaliya School, Parasrampura	no
252	10/8/2021	Himanshu	Shri Rajendra Singh	Dighal, Bidasar Road	9460736369	12 Arts	81	BA - I	Multi Purpose, Jhunjhunu	no
253	10/8/2021	Ramesh	Shri Chouthmal	Nawalgarh	9166922380	12	81	BA - I	Generalism	no
254	17/08/2021	Rakesh Agarwal	Shri Sanjay Agarwal	Ward No. - 16, Mukundgarh	7568287136	12	79	BA - I	Subodh School	no
255	17/08/2021	Ananand Saini	Shri Sitaram Saini	Barwasi, Birol	9672911872	12	80.7	BA - I	Prerna School, Nawalgarh	no
256	19/08/2021	Payal	Shri Tarachand	Ward No. - 9, Mandasi	9785951971	12	79	BA - I	Sr. Sec. School, Mandasi	no
257	19/08/2021	Vikas Kumar	Shri Girdhari Lal Saini	Ward No. - 4, Mohabatsar, Chelasi	9079971932	12	75	BA - I	Mishra, Anthawali Dhani	no
258	19/08/2021	Mukesh Kumar	Shri Banwari Lal	Ward NO. - 5, Chhota Bus Stand	8741058538	12	71	BA - I	Mishra, Anthawali Dhani	no
259	21/08/2021	Sharma Mohit	Shri Jitendra Sharma	Ward No. - 5, Kumawas	8239430325	12	78	BA - I	Sr. Sec. School, Kumawas	no
260	24/08/2021	Pritiksha	Shri Sunil Kumar	Sangasl	9587820350	12	88	BA - I	Sr. Sec. School, Mandasi	no
261	24/08/2021	Anita	Shri Sita Ram	Ward NO. - 23, Mukundgarh	6377872376	12	85	BA - I	Sr. Sec. School, Mandasi	no
262	25/08/2021	Harkesh	Shri Kamlesh	Ward NO. - 16, Khirod	7340458967	12	50			no

ans
Print
th G. B. P.
Luv...

263	25/08/2021	Krishna Kumar	Shri Sanwar Mal	Ward No. - 20, Khirod	7424857650	12	59	BA - I	Govt. School, Khinwasar	Reg. BA - I (Geo)
264	25/08/2021	Mithilesh	Shri Ghanshyam Swar	Ward No. - 5, Khird	9829685165		82	BA - I	Govt. School, Khinwasar	no
265	26/08/2021	Dayanand	Shri Mohanlal	Pratap Pura, JIN	9999894530	MA	45	MA (Geo)	Non - College	no
266	1/9/2021	Ashish Kumar	Shri Mahesh Faran	Pipali Chowk, Nawalgarh	7023148151	12	74	BA - I	Pilani	no
267	1/9/2021	Vijay Kumar	Shri Sumer Singh	Gadhwal Ki Dhani, Khirod	8503838017	12	85	BA - I	Saraswati Bal Niketan, Khirod	no
268	4/9/2021	Anil	Shri Jaikaran	Charan Ki Dhani, Parasrampura	9784507315	12	75	BA - I	Govt. School, JIN	No
269	4/9/2021	Amit	Shri Mahaveer Prasad	Charan Ki Dhani, Parasrampura	9414982624	12	80	BA - I	Bharat Mata Modiya Tibba School	no
270	4/9/2021	Vijay Pratap Singh	Shri Jogendra Singh	Ward No. - 13, Khirod	7300108248	12	82	BA - I	Aadrsh Bal School, Parasrampura	no
271	4/9/2021	Pawan Kumawat	Shri Bhoma Ram Kumawat	Ward No. - 8, Tarpura	9799473218	12	82.8	BA - I	Aadrsh Bal School, Parasrampura	no
272	6/9/2021	Manoj	Shri Birju	Ward No. - 1, Churi Miyan	9460702842	12	70	BA - I	Govt. School, Balaran	no
273	6/9/2021	Rakesh	Shri Hanumana Ram	Ward No. - 4, Balaran	7742490816	12	72	BA - I	Govt. School, Balaran	no
274	6/9/2021	Lal Chandra Meel	Shri Ajit Singh	Kolida	9982890702	12	85	BA - I	Subodh School	no
275	10/9/2021	Ronak Meel	Shri Banwari Lal	Hanuman Ji Dhan, Bugala	9587534939	12	78	MA (Pol. Sci.)	Tagore PG College	no
276	14/09/2021	Rajkumar	Shri Mohal Lal	Tonk Chhillri, Nawalgarh	7691860546	12	69.8	BA - I	Govt. School, Chirawa	No
277	14/09/2021	Rajlaxmi Rai	Shri Subhash Rai	Ward No. - 9, Suryamandal ke Pass	9057245878	12	96	BA - I	Astha Public School, Sikar	No



Principal
Seth G.B. Podar College
Nawalgarh - 333042